

Eccles's Model of Mind-Brain Interaction and Psychokinesis: A Preliminary Study

WILLIAM GIROLDINI

*Associazione Italiana Scientifica di Metapsichica (A.I.S.M.), via S. Vittore 19,
20193 Milano, Italy*

Abstract—In this article the relationship between mind and brain is initially discussed from the opposite materialist and dualist perspectives. In the Eccles's hypothesis, a very weak psychokinetic (PK) action of will on a few neurons of cerebral cortex could determine remarkable changes in brain activity. Starting from this idea, a neuron network suitable for revealing weak PK influences is discussed. Thirty-five preliminary PK experiments based on a Random Signal Generator (RSG), which represents a first raw electronic version of this neuron network, were performed. Twenty-seven subjects attempted to mentally influence the RSG in a double optical and acoustic RSG-feedback. Each experiment was fully computer controlled and consisted of ten PK-minutes alternated with ten control-minutes without feedback. Moreover, the EEG recording of alpha and beta rhythms of subjects during the experiments was performed. The PK experiments gave altogether a significant result ($p < 10^{-3}$), whereas 35 control-experiments without subjects were nonsignificant. EEG analysis showed that during the control-minutes the alpha and beta rhythms were wider than in the PK minutes, and moreover the alpha rhythm was remarkably higher during the PK-hitting than in the PK-missing trials. A psychological interpretation of these results is proposed, but the more interesting possibility is that an independent high alpha activity would cause better PK performance. Further studies are necessary to test this important possibility.

Introduction

What is the relationship between the mind and the brain? The psyche-soma question has always been dominant, but only in recent years has this problem been considered from a variety of perspectives, including physics, neuro-

Acknowledgments. I am very grateful to Dr. Massimo Biondi, Dr. Marco Margnelli and Dr. Carla Sborgi for their suggestions and critical comments. Thanks are due to arch. Elio Silvestri for his skillful assistance in the experimental work. This work has been supported by the Associazione Italiana Scientifica di Metapsichica, via S. Vittore 19, 20123 Milano, Italy.

Correspondence and requests for reprints should be addressed to Dr. William Giroldini, via Pascoli 36F, 20097 S. Donato, Milano, Italy.

physiology, analytical psychology, and parapsychology (Hall and Callander, 1984).

The great progress in our time in the understanding of the physical and biological world has led us to the prevailing conception that living organisms are equivalent from all points of view to very complex machines, constructed with elementary components such as atoms and molecules, whose interactions determine all the properties of living systems.

This interpretation has certainly gathered great successes in the description of life in terms of physiological and biochemical phenomena, for example with the discovery of the material basis of heredity, the DNA molecule. However powerful this approach may be, it nevertheless meets with great difficulties, for example, in the description of mental processes.

Yet the dominant biological reductionism asserts that the mind is only a property of complex systems due to the particular organization of a small number of elements (neurons, synapses, etc.) which act in accordance with the known laws of physics.

In materialist theories the mental is not distinct from the physical, and all mental states, properties, processes, and operations are in principle identical with physical states, properties, processes and operations. The Central-State Identity theory (Fodor, 1981) acknowledges that mental causes can exist, but describes them as being only neurophysiological events in the brain. An extension of this theory is that the psychological constitution of a system seems to depend not on its hardware, or physical composition, but on its software, or program. In fact, the hardware of a system can be based indifferently on neurons, transistors, optical elements and so on, but only the relations among them and the operative programs are important. All the studies in the field of Artificial Intelligence are based on this concept, and in any case it is believed that mental events are only physical events: Nothing is required besides matter to explain the mind and consciousness (Griffith, 1967; Sperry, 1961).

Different viewpoints have been expressed, however, by a great many of the luminaries of consciousness research, including Jung (1950, 1969), Pribram (1968), Penfield (1960), Eccles (1953, 1965), Mattuck (1982), Walker (1975), Jahn and Dunne (1986), and Bohm (1986), among others. They claim that atoms and molecules do not constitute the ultimate reality, but that matter is only the physical support on which act new kinds of energies and organizational forces not derivable from it, i.e., the physical world is only a partial aspect of reality.

This conception (philosophical dualism) introduces a fundamental branching of nature: On one side there is matter, on the other side, mind and consciousness. Examples of this conception are Jung's notion of the "Collective Unconscious," and the mind-matter interaction theories of Walker, Mattuck, and Jahn and Dunne, based on a particular interpretation of Quantum theory.

The Mind-Brain Relation

The aim of this article is not to illustrate these different philosophies, but to describe and develop a very interesting idea proposed by John Eccles, eminent neurophysiologist and Nobel prize winner in 1963 for his pioneering work on the transmission of nervous impulses across the synapses of nervous cells. In the last chapter of his book *The Neurophysiological Basis of Mind* (1953), Eccles not only hypothesized the existence of a "self-conscious mind" relatively independent of the cerebral structures, but also supposed that a very weak influence of will on a few neurons of the cerebral cortex could cause remarkable changes in brain activity.

Starting from Eccles's idea, let us ask how we can, for example, produce a voluntary muscular movement. Modern neurophysiology can give us very many of the details about the biochemical and bioelectrical processes involved in this simple action. Since a muscular movement can also be produced by an artificial stimulation of the motor cortex, this fact commonly leads to mechanistic interpretation.

But Eccles found that subjects reported "feeling" a significant difference between such acts and willed ones. In Eccles's view, each exercise of conscious will is accomplished by a typical pattern of excitation in the brain.

The initial influence of the will on specific neurons might be very slight in terms of actual energy, but sufficient to cause a chain of neurophysiological events culminating in the desired action. The question then arises, how is the will able to influence this group of neurons?

A possible answer is that "will" and "consciousness" are only abstract concepts and that the human brain, with its own array of feedback mechanisms, considers itself to be endowed with "feeling", "will" and "consciousness." But these are only nervous circuits, so it does not make sense to ask how the will acts, since the will does not truly exist: only atoms, molecules and nervous cells exist. In other words, although we apparently are always free to decide a certain voluntary action, in reality this is only a pseudochoice since the brain activity, in each moment, is only the probabilistic result of all its previous mental activities (Lashley, 1963; Griffith, 1967).

On the other hand, Eccles attributed true causal action to the mind and suggested that psychokinesis could be implicated in the relationship between mind and brain. In fact, to explain the mind-brain interface, Eccles argued that there should be some kind of direct interaction channel between the mind and brain, and PK could most likely be this channel.

Generally, if we accept the real existence of psi, then a complete reduction of mind and consciousness to a purely physical phenomenon, as postulated by the orthodox view, would be impossible.

The Neurophysiology of Consciousness

From the neurophysiological viewpoint, we know that the cerebral cortex and the reticular formation of the cerebral stem are essential for the integra-

tion of sensory information into a conscious experience. The process which causes the consciousness seems to be controlled by the cerebral stem, because this is the only part of brain where an injury causes a loss of consciousness (Fessard, 1954; French, Hernandez-Peon and Livingston, 1955).

According to Moruzzi's model (Moruzzi, 1972), the flux of impulses coming from the reticular formation and bound for the cortex regulates the various states of consciousness, including **waking**, sleep, and coma. In the waking state, a wide inhibitory network acts on all the levels of the Central Nervous System (CNS) in order to allow a selective facility of attention on a specific object. Some cerebral structures, such as the reticular mesencephalic formation and the limbic system, modulate the sensorial stimuli by selectively opening or closing their passage towards the consciousness.

In the dream state, the input of sensorial stimuli into the CNS is reduced, while conscious experiences (dreams) are accentuated. In this case the information arrives at the conscious experience system from the cortical areas of memory which are normally inhibited during **waking**. The **neurophysiological** model of dreams can be applied by analogy also to the mechanism of hallucinations which appear in various circumstances and without specific cause.

At any rate, present neurophysiological knowledge does not allow us to resolve the problem of the intimate nature of the consciousness, although the majority of scientists working in field of Artificial Intelligence would be confident of the possibility of constructing a thinking machine (Searle, 1990; Churchland and Churchland, 1990).

A Review of PK Experiments with Random Number Generators (RNG)

A good review of PK experiments through 1976 was discussed by Stanford (1977). In the last 10 years, several investigators reported positive results in PK experiments based on RNG, for example, **Bierman (1985)**, **Varvogliis and McCarthy (1986)**, **Michels (1987)**, and **von Lucadou (1987)**.

These authors, in particular, found that the PK success rate was higher in the feedback than in the nonfeedback condition.

At Princeton University, **Jahn, Dunne, and Nelson (1987, 1988)** have performed, in a period of six years, important and accurate studies on PK using RNG or mechanical devices. They obtained significant results and found that a Random Event Generator (in general) can be mentally influenced according to preselected direction (**PK+**, **PK-**).

On the other hand, **von Lucadou**, in his multivariate PK study, found that the **sheep/goat** paradigm is the more important psychological variable correlated with PK ability.

These recent works confirm substantially the results obtained by other researchers, such as **Cox (1974)** and **Schmidt (1970)**, among others.

Of particular importance concerning **Eccles's** idea are studies where the relationship between the EEG activity of a subject and its PK influence on a RNG was examined.

Schmidt and Terry (1976) performed PK tests where a trial was initiated only when the brain was in the specific state Alpha or Beta. The subjects received immediate sound feedback from the binary RNG. The results indicated that subjects were successful in producing PK hits in both Alpha and Beta trials.

Heseltine (1977) and Heseltine and Mayer-Oakes (1978), described exploratory experiments in which a specially designed RNG was coupled to EEG activity of a subject by means of a computer.

More specifically, the EEG activity was used to initiate a PK trial with and without RNG feedback (through headphones). Only the feedback runs were significant, and moreover, the deviation obtained was associated with the Alpha activity and high Beta frequencies (18–34 Hz).

A preliminary test of Eccles's hypothesis was performed by Honorton and Tremmel (1978). A binary noise-driven RNG served to detect PK activity in relation to the subject's efforts to influence his own EEG activity through biofeedback. The subject's volitional task was to remain in the Alpha state as much as possible. PK scores were significantly higher in the alpha condition than in the non Alpha condition, but other observations suggested a relationship between PK and EEG feedback rather than an intrinsic relationship between PK and Alpha activity.

Finally, Varvoglis and McCarthy (1986) found significant PK results not only when the subjects tried to influence the RNG and received feedback from it, but also when they were task oriented, and received feedback, from their EEG, while data were collected from an unknown, "hidden" RNG.

These authors conclude that both intended and incidental PK effects may be obtained by individuals' conscious-purposive focus.

A Neurophysiological Model of PK Detector

Following Eccles' idea, is it possible to imagine a neuron network able to reveal weak PK influences and consequently to start the motor functions controlled by the will?

This hypothetic network must supply an almost deterministic output (of the type "none-or-all") in a time of approximately 0.1–1 seconds and with high selectivity about the particular network influenced by the PK.

These two requisites are indispensable if the Eccles's hypothesis is true.

Let us consider the scheme of Figure 1: A_1, A_2, \dots, A_n are a certain number N of neurons which spontaneously discharge (fire) at the mean frequency F_1 (impulses/sec).

We hypothesize moreover that the firing of a neuron A is fully independent of the others neurons, and that the width of the impulse would be small in comparison to the mean distance $\Delta T = 1/F_1$ between two impulses. These neurons are connected with neuron B , which discharges only if all the N neurons simultaneously fire within the time interval ΔT_0 . If we suppose that $\Delta T_0 \leq \Delta T/2$, then there is the probability $p = \Delta T_0/\Delta T$ to observe an

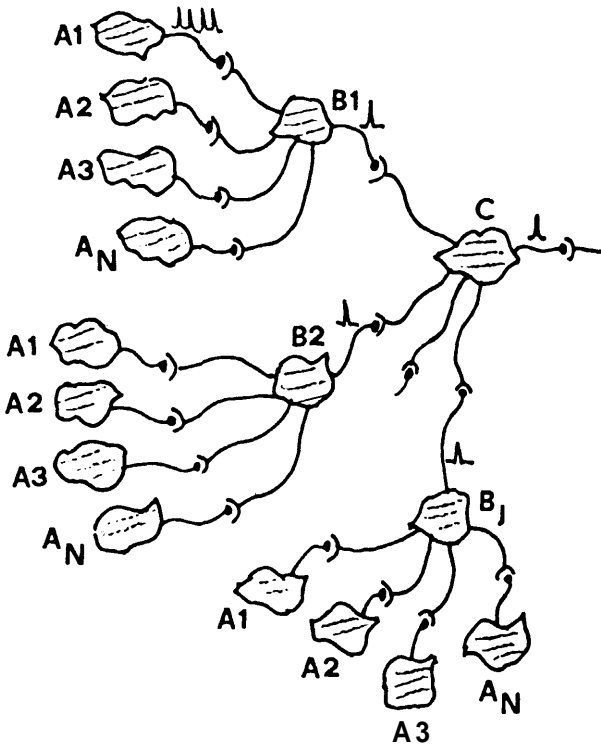

Fig. 1. Scheme of a possible neuron network able to reveal weak psychokinetic influences.

impulse from a single neuron A within the time interval ΔT_0 , and the probability to observe N contemporaneous discharges is $p = (\Delta T_0 / \Delta T)^N$. The firing rate of neuron B is then $F_2 = ((\Delta T_0 / \Delta T)^N) / \Delta T_0 = ((\Delta T_0)^{N-1}) * (F_1^N)$ impulses/sec. A certain number J of B neurons are moreover connected with neuron C which acts by integrating the impulses coming from $B_1 \dots B_j$ neurons.

When the number of impulses per second exceeds a determinate firing threshold, C generates an impulse.

Selecting the following reasonable values: $F_1 = 1000$ Hz, ($\Delta T = 1$ ms); $\Delta T_0 = 0.5$ ms; $N = 16$; $J = 660$, we can calculate that the neuron C will receive 20 ± 4.5 impulses per second from all the B neurons. We suppose now that PK acts on the $A_1 \dots A_n$ neurons increasing lightly their firing rate, for example from $F_1 = 1000$ Hz to $F_1 = 1045$ Hz. On account of this weak frequency increment, neuron C will receive about 40 ± 6.3 impulses/sec.

If the firing threshold of C is fixed at 35–40 impulses per second, then it will discharge nearly exclusively when the PK causes an increment of F_1 equal or superior to 4.5%. This increment is in the range obtained in some

PK experiments with RNGs. In 1989 I discussed another possible neuron network organized to reveal weak PK effects (Giroladini, 1989).

There is still another way for the hypothetical action of PK on the neuron network presented in Figure 1. In this second way, perhaps more interesting than the first, the mean discharge frequency of the $A1 . . . An$ neurons is unaltered and PK acts only on the "phase degree" or "phase matching" among the neurons's impulses. If the $A1 . . . An$ neurons discharge more synchronously than randomly expected, the net result would be an increase of the discharge frequency of the $B1 . . . Bj$ neurons, etc., as previously described. However I have not, as yet, developed a mathematical description of this second possibility.

The second problem, i.e., the selectivity of PK on a particular neuron network, could be resolved with the concept of "feedback." The nervous system widely utilizes different types of feedback circuits, that is to say retro-active circuits which control, modulate, and stabilize the nervous activity. In particular a negative feedback is necessary in our model.

This kind of feedback is controlled by the "error" and it acts to bring the system toward the aim, or purpose, of the operation. In our case, for example, the aim is represented by a specific voluntary muscular movement.

Feedback is important not only in neurophysiology, but also in PK experiments, as shown in the preceding literature review. Other experimental studies have demonstrated that learning efficiency increases considerably when the time interval between the answer and feedback is of the order of one second or less (Tart, 1975, 1977).

In fact, it is well known that the contents of consciousness change in a characteristic way in a time of about 0.1 seconds, which corresponds to the more important cerebral frequencies, i.e., the alpha and beta rhythms. Since the feedback is based on the consciousness, it is very probable that the greatest efficiency of PK on an RNG or similar device would be obtained using a fast feedback.

Experimental Part

The neuron network previously discussed leads to the possibility to experimentally test Eccles's model in a new perspective. In particular, it is possible to make an electronic circuit simulating this network.

During the years 1989–1991 I have performed several preliminary PK experiments based on a Random Signal Generator (RSG) which represents a raw electronic version of the neuron network of Figure 1. In order to obtain further information, an electro-encephalographic recording of alpha and beta rhythms of the subjects was also performed during the experiments.

Random Signal Generator

The RSG was comprised of three identical circuit blocks. Each block was made up of 12 logical circuits (type INVERTER) working as "free oscilla-

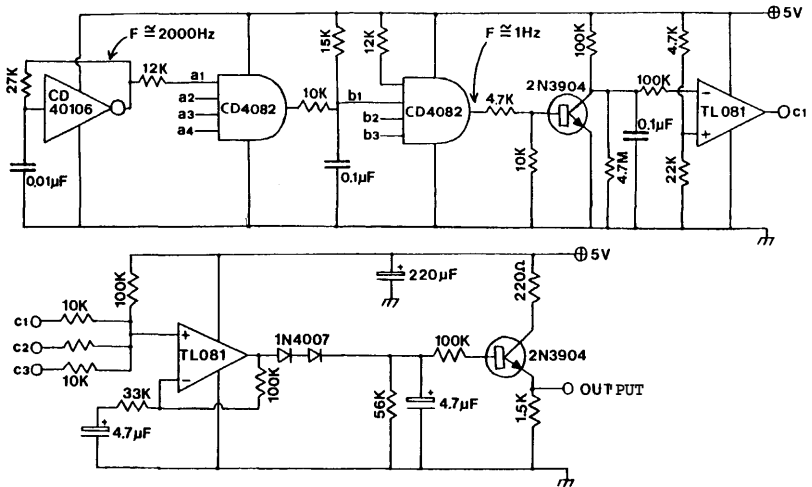

Fig. 2. Scheme of the Random Signal Generator used for the PK experiments. The input-terminals a2, a3, a4 of integrated circuit CD4082 are connected like the terminal a1. Analogously, terminals b2 and b3 are connected like b1, and c2, c3 are circuits like c1. All the C-MOS integrated circuits type CD40106, CD4082 and the FET operational amplifier type TL081 were Motorola trademark. The 5-volt power source is from a voltage-stabilizer integrated type 7805.

tors" at the frequency of about 2000 Hz. Four oscillators were connected with a 4-inputs logical circuit type AND, and its output, after elimination of the impulses having minor width of about 0.20 milliseconds, was connected with another AND circuit, as shown in Figure 2. The sharp impulses coming from this second AND circuit were increased up to 100 milliseconds, added up and integrated in the time. Several accurate controls showed that this output signal was a true random signal, that is to say its pattern is always different in the time, but statistically reproducible and closely normally distributed.

The RSG circuit was accurately shielded inside an aluminum box and moreover, thermostated at the temperature of 40 ± 0.2 C. These precautions provided a good protection against the temperature variations in the room and electromagnetic interferences.

Electro-Encephalographic Recording

EEG was recorded by means of three Ag/AgCl electrodes, two of them placed on the frontal lobes of subject and the third one at the centre of the forehead (reference electrode), and using a differential configuration. The frontal lobe location was chosen mostly because here it is easier to place the electrodes without disturbing the subject. A low-noise preamplifier with 3–30 Hz band-pass and high differential impedance input ($4.7 \text{ M}\Omega$) was used. Great care was taken in order to minimize the 50 Hz electromagnetic

noise by means of a careful grounding of all electronic devices. The amplified signals were filtered in alpha (7.5–13 Hz) and in beta band (13–25 Hz). The output of the two filters was rectified giving a signal proportional in every moment to the amplitude of alpha and beta rhythms.

The subjects were instructed to minimize their head movements during the experiments. In any case, it was verified that the muscle movements gave signals mostly in the range of 0.5–4 Hz, so that the alpha and beta band were relatively free of artefacts.

Data Acquisition System

Experiments were entirely controlled by an IBM AT computer. The signals coming from the three variables (the RSG and the alpha and beta filters) were sent to an 8-bit analog to a digital converter mounted in the computer. Data were sampled at a rate of 20s/second/variable, and every 0.75 seconds the average was calculated. These averaged values were stored in the memory of the computer and recorded on floppy diskettes at the end of each experiment. Because each experiment lasted 20 minutes, in total 4800 data per experiment were collected, which corresponds to 80 data/minute/variable.

Experimental Procedure

In this PK experiment, a person attempted to mentally influence the RSG generator in double RSG-feedback condition, both by observing a graphic displayed on a monitor and by listening to an acoustic note. Feedback was updated every 0.75 seconds.

The graphic could randomly go up or down on the monitor, and it was traced by the computer using the signal from the RSG.

The task of a subject was to mentally push the graphic in a preselected direction, for example up. There was a direct relation between the feedback and the RSG signal: an increment of the signal amplitude pushed up the graphic and the frequency of the note, and vice versa.

The graphic required one minute to be completed on the monitor (PK minute) and after this time, it was followed by a minute without feedback. This was called "control minute" and in this interval the graphic and the sound were absent, but the computer continued to collect data as in the PK minute. During the control minute, the subject was instructed not to attempt to influence the RSG, but only wait for the next minute.

The alternation between the "PK minute" and the "control minute" was important in these experiments, because this assured high homogeneity of the surrounding conditions.

Moreover, the "control minute," is useful because it allows the subject to break the psychological tension derived from the task. All the experiments (or trials) were made up of 10 PK minutes and 10 control minutes. Several control experiments were also performed. In this case, no one was present in the experiment room, but the data from the RSG were collected with the

identical program used when a person was present in the room. In order to simulate as closely as possible the situation of PK experiments, EEG signals were generated using an EEG prerecorded on tape.

Selection of Subjects

The subjects were selected only on the basis of their belief in ESP/PK and enthusiasm for the experiments; skeptical subjects or subjects barely interested in experiments were rejected a priori. In my opinion, this criterion increases the probability of success of the experiments. No relaxation training was used before the experiments. Subjects were free to select whether the target would be up or down, according to their preference, because the imposition of a certain target could negatively influence the subject's mood (this was observed in preliminary informal experiments). In any case, an eventual unbalanced number of up and down targets did not constitute a problem for the statistical analysis of data.

More generally, the psychological motivation of subjects was considered to be very important, because we were testing a "will" or an "intention" versus the chance.

Statistical Analysis

The statistical analysis was based on the search for a significant difference, if there was any, between the 10 PK minutes and the corresponding 10 control minutes of each experiment. In the main analysis, it was calculated that the significance of the difference between the mean amplitude of RSG signal in the 10 PK minutes and the 10 control minutes using the t-test of Student (two-tailed). This analysis utilized the 800 + 800 data of each experiment. The same approach was used for the no-subject experiments. The statistical analysis of the EEG was performed by calculating the alpha and beta amplitude average of each minute, and the standard deviation per minute. The differences between groups of data were appraised using the Student's t-test (two-tailed). The statistical analysis of EEG was performed only in the PK experiments, there being a lack of sense in the analysis of the prerecorded EEG of the no-subject experiments. For sake of simplicity, we will refer also to the PK experiment and no-subject experiment as PK trial and Control trial respectively.

Results

Till now, 35 PK trials and 35 Control trials were performed by 27 subjects. I was one of the subjects. Tables 1 and 2 show the results of the experiments. The control trials gave no significant total result, although three trials were significant. Five PK trials were significant ($p = 0.05$ to 0.002), and if we

TABLE 1
Thirty-five PK trials

Trial	Delta%	Significance	Target	Subject
PK01	-0.24	n.s.	PK+	G.W.
PK02	-0.84	n.s.	PK+	G.W.
PK03	0.29	n.s.	PK+	G.W.
PK04	-0.96	$P = 0.19$	PK+	G.W.
PK05	1.74	$P = 0.10$	PK+	M.L.
PK06	1.59	$P = 0.16$	PK+	B.D.
PK07	0.79	n.s.	PK+	C.C.
PK08	-0.56	n.s.	PK+	M.V.
PK09	-1.23	n.s.	PK-	M.V.
PK10	-2.37	$P = 0.004$	PK-	B.R.
PK11	3.52	$P = 0.002$	PK+	G.E.
PK12	-1.54	$P = 0.14$	PK+	F.M.
PK13	0.96	n.s.	PK+	G.A.
PK14	1.88	$P = 0.06$	PK+	M.A.
PK15	-1.88	$P = 0.07$	PK+	C.M.
PK16	1.02	n.s.	PK+	C.A.
PK17	0.47	n.s.	PK+	G.G.
PK18	1.06	n.s.	PK+	F.F.
PK19	0.01	n.s.	PK+	F.F.
PK20	-1.36	n.s.	PK-	F.F.
PK21	-1.58	$P = 0.18$	PK-	T.M.
PK22	-1.03	n.s.	PK-	G.A.
PK23	1.53	$P = 0.05$	PK+	G.E.
PK24	-1.73	$P = 0.07$	PK-	G.A.
PK25	-1.79	$P = 0.06$	PK-	M.L.
PK26	1.46	$P = 0.12$	PK+	G.W.
PK27	-0.14	n.s.	PK-	V.S.
PK28	0.79	n.s.	PK+	N.S.
PK29	-3.53	$P = 0.004$	PK-	L.B.
PK30	0.51	n.s.	PK-	C.M.
PK31	0.55	n.s.	PK+	E.R.
PK32	-0.01	n.s.	PK+	S.C.
PK33	-1.25	n.s.	PK-	C.F.
PK34	0.34	n.s.	PK+	F.L.
PK35	0.70	n.s.	PK-	G.P.

Note: "Delta%" is the percent difference between the mean amplitude of RSG signals in the 10 PK minutes and the 10 control minutes of each experiment. Mean difference in the preselected direction: 0.764%.

Standard deviation percent of RSG in the PK minutes: 19.9%.

Standard deviation percent of RSG in the control minutes: 20.0%.

Number of data: $800 * 35$.

consider the mean difference in the preselected direction, the whole result was significant at level of $p < 0.00001$, as shown in Figure 3.

The analysis of EEG alpha and beta band (Table 3 and Figure 4) shows a significant difference between the average amplitude of alpha rhythm during the PK minutes and the control minutes ($p \ll 0.001$). This difference is significant also in the beta band ($p \ll 0.001$), so that we can conclude that

TABLE 2
Thirty-five control trials (no subject)

Trial	Delta%	Significance
CT01	1.98	$P = 0.02$
CT02	0.90	n.s.
CT03	0.96	n.s.
CT04	-0.56	n.s.
CT05	-0.23	n.s.
CT06	-0.31	n.s.
CT07	-0.68	n.s.
CT08	-1.08	$P = 0.15$
CT09	1.20	$P = 0.13$
CT10	0.96	n.s.
CT11	-0.68	n.s.
CT12	-1.07	n.s.
CT13	-0.06	n.s.
CT14	-1.74	$P = 0.13$
CT15	-1.37	n.s.
CT16	0.76	n.s.
CT17	-0.16	n.s.
CT18	1.60	$P = 0.13$
CT19	0.76	n.s.
CT20	0.86	n.s.
CT21	0.08	n.s.
CT22	-0.54	n.s.
CT23	0.08	n.s.
CT24	0.04	n.s.
CT25	0.58	n.s.
CT26	-2.28	$P = 0.03$
CT27	-0.36	n.s.
CT28	-1.21	n.s.
CT29	-0.55	n.s.
CT30	0.18	n.s.
CT31	0.55	n.s.
CT32	-2.19	$P = 0.02$
CT33	-0.23	n.s.
CT34	-0.31	n.s.
CT35	1.86	$P = 0.07$

Mean difference percent: -0.06% .

Standard deviation percent, PK minutes: 20.3% .

Standard deviation percent, control minutes: 20.4% .

Number of data: 800×35 .

during the control minutes the EEG was significantly wider than in the PK minutes. In particular, we can observe a clear jump of EEG amplitude at the beginning of the control minute, followed by a progressive diminution until the beginning of the next PK minute.

The positive result obtained in PK experiments suggested looking for differences in EEG between PK-success and PK-miss trials. Table 4 shows a kind of analysis where 8 trials with $p < 0.1$ are compared with the remaining

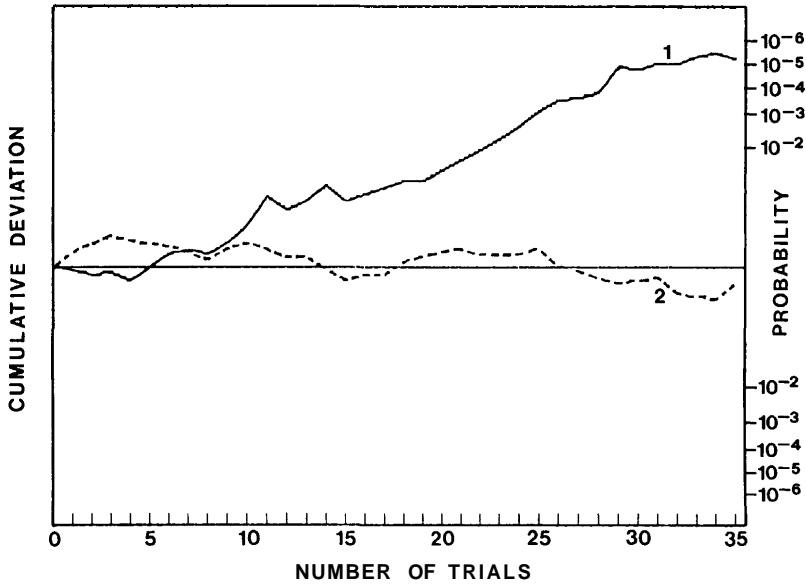

Fig. 3. Cumulative deviation for 35 PK trials (graph 1) and 35 Control trials (graph 2).

27 trials, while Table 5 shows the comparison of 25 successful trials in direction of intention versus 10 opposite direction trials.

In both cases, the average value of alpha is significantly wider during the PK-success trials than in the PK-miss trials ($p < 0.001$), according to the respective definition of a PK-success trial.

Discussion

The primary PK effect found in this research was a small but significant difference of the order of 1% between the PK and Control minute.

A consideration is important in order to interpret this result: the subjects probably did not fully stop their PK action at the end of each PK-minute, and also the Control-minute was affected by PK (at an unconscious level) so

TABLE 3

Mean amplitude of alpha and beta EEG based on 350 PK minutes and 350 control minutes. All values are in microvolts, and *sd* = standard deviation per minute.

	PK minute		Control minute	
Alpha	9.34	sd = 3.42	12.5	sd = 3.47
Beta	16.78	sd = 8.08	19.42	sd = 6.89

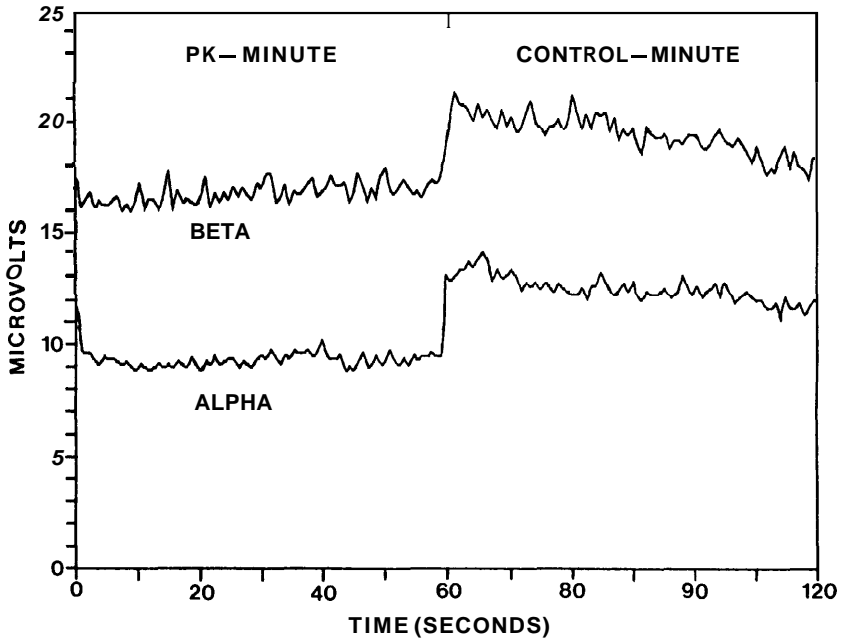

Fig. 4. Mean amplitude of Alpha and Beta EEG during the PK and control minute. The graphic is based on 35 PK trials. Notice the jump of EEG amplitude at the beginning of control minute.

that we can suppose that the experiments actually tested the PK-feedback versus the PK-nonfeedback action.

In my opinion, this result confirms the possibility of mentally influencing an RSG (or RNG), and is in agreement with the Eccles's hypothesis, because it demonstrates that volition can trigger PK effects.

On the other hand, it is difficult to say whether the particular RSG used here is better than other types of RSG or not, because no comparison is possible.

The analysis of EEG data showed that during the control minutes the EEG was wider than in the PK minutes. This was systematically found for all the subjects, but it is not a surprising result because there is a great perceptual

TABLE 4
Mean amplitude of alpha in the 8 trials with $P < 0.1$ and in the 27 trials with $P > 0.1$.

8 PK-success trials	27 PK-miss trials
Alpha (PK min.) = 10.72 <i>sd</i> = 3.7	Alpha (PK min.) = 8.93 <i>sd</i> = 3.2
Alpha (CT min.) = 13.57 <i>sd</i> = 3.2	Alpha (CT min.) = 12.19 <i>sd</i> = 3.5
Number of data: 80	Number of data: 270

TABLE 5
Mean amplitude of alpha in the 25 trials in direction of intention and in the 10 trials in opposite direction.

25 PK-success trials	10 PK-miss trials
Alpha (PK min.) = 9.74 sd = 3.5	Alpha (PK min.) = 8.35 sd = 3.1
Alpha (CT min.) = 13.17 sd = 3.4	Alpha (CT min.) = 10.83 sd = 3.1
Number of data: 250	Number of data: 100

stimulus difference between the PK and control condition. At variance with the control minute, the PK minute has visual and auditory feedback, although in both cases the subjects had open eyes and were in the normal consciousness state. Moreover, it is very likely that during the PK minute the PK-task caused an increase of the anxiety (or apprehension) level. Indeed, it is well known that the alpha rhythm is depressed by anxiety and concentration in a generic task. During this phenomenon (called "desynchronization"), there is an upward shift in frequency together with a voltage drop, and consequently a decrease in the beta band amplitude.

A more interesting question arises about the cause of the alpha rhythm average increment during the PK-success trials (according to the two definitions of "PK-success" previously given). Above all, this result is in accordance with the work of Heseltine and Honorton, who found a significant relationship between PK-hit and alpha activity.

It seems impossible to decide, on the basis of this data, if an intrinsically high alpha level caused better PK performance or vice versa. In fact, under a PK-feedback condition, we cannot exclude that an independent PK-hitting situation would increase the alpha activity by means of a psychological factor, for example the emotional activation derived from the success in PK task. On the contrary, a PK-missing situation presumably can cause an emotional deactivation, i.e., depression and anxiety arousal, that could lead to diminution in alpha activity.

From the parapsychological viewpoint, it would be very interesting to demonstrate that an independent high alpha activity can cause better PK performance. Since we know how to increase the alpha rhythm (for example, by means of biofeedback or meditation training) this could lead to the possibility of stimulating the PK by a simple technique.

The pilot study of Honorton and Tremmel (1978) to test the psi component of volition, found that in alpha feedback (i.e., alpha was the independent variable) the PK scores were significantly higher than in a nonalpha condition: this result is very important but certainly requires further confirmation. I can only add another observation: the subjects who showed more anxiety before the PK experiment failed the trial.

Mind-matter interaction is a very interesting and important open problem

with possibly considerable consequences on Quantum Theory. Research in this direction should be encouraged.

References

- Bierman, D.** (1985). A retro and direct PK test for babies with the manipulation of feedback: A first trial of independent replication using software exchange. *European Journal of Parapsychology*, 5, 373-390.
- Bohm, D.** (1986). A new theory of the relationship of mind and matter. *Journal of American Society for Psychical Research*, 80, 113-136.
- Churchland, P. M., & Churchland, P. S.** (1990). Could a machine think? *Scientific American*, 262(1), 32-39.
- Cox, W. E.** (1974). PK tests with a thirty-two channel balls machine. *Journal of Parapsychology*, 38, 56-68.
- Eccles, J.** (1953). *The Neurophysiological Basis of Mind*. Oxford: Clarendon Press.
- Eccles, J.** (1965). *The Brain and the Unity of Conscious Experience*. Cambridge: Cambridge University Press.
- Fessard, A.** (1954). Mechanisms of nervous integration and conscious experience. In *Brain Mechanisms and Consciousness*. J. F. Delafresnaye (Ed.), Springfield: Charles C. Thomas.
- Fodor, A. J.** (1981). The mind-body problem. *Scientific American*, 244(1), 124-132.
- French, J. D., Hernandez-Peon, R., & Livingston, R. B.** (1955). Projection from cortex to cephalic brain stem (reticular formation) in monkey. *Journal of Neurophysiology*, 18, 74.
- Giroldini, W.** (1989). Mente, corpo ed ESP/PK: un possibile test sperimentale per un modello unitario. *Metapsichica*, 23-39.
- Griffith, J. S.** (1967). Neural organization underlying conscious thought. *Nature*, 214, 345-348.
- Hall, A., & Callander, E.** (translated by; 1984). *Science and Consciousness: Two Views of the Universe*, M. Cazenave (Ed.). Elmsford, New York: Pergamon Press.
- Heseltine, G. L.** (1977). Electronic random number generator operation associated with EEG activity. *Journal of Parapsychology*, 41(2), 103-117.
- Heseltine, G. L., & Mayer-Oakes, S. A.** (1978). Electronic random number generator operation and EEG activity: Further studies. *Journal of Parapsychology*, 42(2), 123-136.
- Honorton, C., & Tremmel, L.** (1978). Psi correlates of volition: a preliminary test of Eccles' "neurophysiological hypothesis" of mind-brain interaction. *Research in Parapsychology*, 36-38.
- Jahn R. G., & Dunne, B. J.** (1986). On the Quantum Mechanics of consciousness, with application to anomalous phenomena. *Foundations of Physics*, 16, 721.
- Jahn, R. G., Dunne, B. J., & Nelson, R. D.** (1987). Engineering Anomalies research. *Journal of Scientific Exploration*, 1, 21-50.
- Jahn, R. G., Dunne, B. J., & Nelson, R. D.** (1988). Operator-related anomalies in a random mechanical cascade. *Journal of Scientific Exploration*, 2, 155-179.
- Jung, C. G.** (1950). *Aion*. Zurich: Ed. Rascher Verlag.
- Jung, C. G.** (1969). *The Archetypes and the Collective Unconscious*. (translated by R. F. C. Hull). Princeton: Princeton University Press.
- Lashley, K. S.** (1963). *Brain Mechanisms and Intelligence*. New York: Dover Books.
- Mattuck, R.** (1982). A crude model of the mind-matter interaction using Bohm-Bub hidden variables. *Journal of the Society for Psychical Research*, 51, 238-245.
- Michels, J. A.** (1987). Consistent high scoring in self-test PK-experiments, using a stopping strategy. *Journal of the Society for Psychical Research*, 54(807), 119-129.
- Moruzzi, G.** (1972). *The Sleep-Waking Cycle*. In *Ergeb. Physiol., Berlin Heidelberg, & New York: Springer-Verlag*.
- Penfield, W.** (1960). *The Mystery of Mind*. Princeton: Princeton University Press.
- Pribram, K.** (1968). *Psychology of the Frontal Lobes*. New York: Academic Press.
- Schmidt, H.** (1970). A PK test with electronic equipment. *Journal of Parapsychology*, 34, 175-181.
- Schmidt, H., & Terry, J. C.** (1976). Search for a relationship between brainwaves and PK performance. *Research in Parapsychology*, 30-32.

- Searle, J. R. (1990). Is the brain's mind a computer program? *Scientific American*, 262(1), 26-31.
- Stanford, R. G. (1977). Experimental psychokinesis: A review. In B. Wolman (Ed.), *Handbook of Parapsychology*. New York: Van Nostrand Reinhold.
- Sperry, R. W. (1961). Cerebral organization and behaviour. *Science*, 133, 1749-1757.
- Tart, C. T. (1975). The application of learning theory to ESP performance. New York: Parapsychology Foundation.
- Tart, C. T. (1977). Toward conscious control of psi through immediate feedback training: Some consideration of internal processes. *Journal of American Society for Psychological Research*, 71, 375-408.
- Varvoglis, M. P., & McCarthy, D. (1986). Conscious-purposive focus and PK: RNG activity in relation to awareness, task-orientation, and feedback. *Journal of American Society for Psychological Research*, 80, 1-29.
- von Lucadou, W. (1987). A multivariate PK experiment. Part III. Is PK a real force? The results and their interpretation. *European Journal of Parapsychology*, 6, 369-428.
- Walker, E. H. (1975). Foundations of parapsychological and parapsychological phenomena. In L. Oteri (Ed.), *Quantum Physics and Parapsychology*. New York: Parapsychology Foundation.