

The Effect of Alternative Healing Therapy on the Regeneration Rate of Salamander Forelimbs

DANIEL P. WIRTH, CATHY A. JOHNSON, JOSEPH S. HORVATH,
JO ANNE D. MACGREGOR

Healing Sciences Research International, 29 Orinda Way, Box 1888, Orinda, CA, 94563

Abstract— The following experiment examined the effect of noncontact therapeutic touch (NCTT) on the regeneration rate of salamander forelimbs surgically amputated through the distal third of the stylopodium. A total of 154 newts, *Notophthalmus viridescens*, were used and limb regeneration was assessed using two criteria: (1) the time to first finger differentiation, and (2) the time to fourth finger differentiation. The experiment was divided into two sections. For section #1, four NCTT healers worked individually under three separate conditions in a specially designed laboratory. The conditions were: (1) treatment through an opening in the wall, (2) treatment through smoked opaque glass, and (3) treatment through smoked opaque glass and plastic. For section #2, the four individual healers were paired, with each pair working together on a tank of newts situated directly in front of them. The results for section #1 showed that: (1) Healer 1 obtained non-significance for all three conditions at both the first and fourth finger differentiation stages, (2) Healer 2 obtained significance for all three conditions at both differentiation stages, (3) Healer 3 obtained significance for condition 1 only at both differentiation stages, and (4) Healer 4 obtained significance for conditions 2 and 3 at both differentiation stages. For section #2, only the pair of Healer 1-Healer 3 obtained significant results ($p < .002$). The data, therefore, suggest that NCTT may have the potential to accelerate the rate of regeneration of newt forelimbs surgically amputated through the distal third of the humerus.

Introduction

The phenomenon of regeneration has fascinated man since antiquity. The earliest historical reference to regeneration may be that recorded by Aristotle in his *De Generatione Animalium* written over 2000 years ago (Platt, 1910; Schmidt, 1968). The first detailed scientific analysis of the phenomenon was conducted by Spallanzani, an Italian priest and scientist, in 1768 (Iten and Bryant, 1973). Since that time, many highly esteemed researchers have explored the realm of regeneration including Dr. Marcus Singer and the Nobel Prize laureate Thomas Hunt Morgan.

Regeneration has been defined as the replacement of lost body parts by new outgrowths or by remodelling of existing tissue and has been studied in detail for centuries (Kiortsis, Koussoulakos, and Wallace, 1988; Singer, 1952). Regeneration of body parts is an ability shared, to a varying degree, by all living things. In general, the more advanced along the evolutionary scale an organism is, the more restricted the regenerative ability. In man, for example, the process is normally considered to be limited to certain tissues and organs, including skin and bone (Liozner, 1974;

Singer, Weckesser, Geraudie, Maier, and Singer, 1987). Prior research, however, has indicated that children have the ability to regenerate a functional and morphologically exact replica of a fingertip accidentally severed at the outermost joint (Douglas, 1972; Illingworth, 1974; Louis, Palmer, and Burney, 1980). Full repair, including the finger whorls, takes approximately 12 weeks and is best accomplished with a periodic cleansing and dressing of the wound with no additional therapeutic intervention. Although accounts of fingertip regeneration have generally been limited to children 11 years of age or younger, this may be due to the fact that relatively few older children and adults enter hospitals with amputated fingers (Illingworth, 1974).

The majority of regeneration research conducted in the laboratory has concentrated on the newt, *Notophthalmus viridescens* (Dearlove and Dresden, 1976; Schauble and Nentwig, 1974; Wallace, 1981). The newt, commonly known as the salamander, is a direct descendant from the evolutionary prototype of all land vertebrates and is a fascinating animal which is almost as physiologically complex as a human. The forelimb of the salamander, for example, is essentially the same as ours—with an ulna, radius, a complex nervous system, etc.—yet the animal possesses the unique ability to regenerate its entire limb. In addition, the salamander can regenerate a severed tail, the lens of its eye, and even the spine itself if required (Davis et al., 1990; Grigorian, Dol'nikova, and Belkin, 1990; Thouveny, Komorowski, Arsanto, and Carlson, 1991). Prior research has also demonstrated that when up to 50% of the newt's ventricular myocardium is surgically removed and the body cavity sutured, the cells adjacent to the injured area undergo mitosis and have the characteristics of cardiac fibers (Oberpriller and Oberpriller, 1971). This fascinating regenerative process allows the newt's heart to resume slow circulation within 3–5 hours after resection (Becker, Chapin, and Sherry, 1974).

The current experiment was conducted in order to examine the effect of therapeutic touch (TT) on the regeneration rate of salamander forelimbs surgically amputated through the stylopodium. The TT method, which is based on the ancient healing practice of laying on of hands, was originated by Dr. Dolores Krieger as an adjunct to traditional medical care (Heidt, 1991; Krieger, 1975, 1990; Krieger, Peper, and Ancoli, 1979). Krieger (1979) postulated that TT achieved its effect by an interaction of energy fields between the practitioner and subject. As commonly practiced, the TT practitioner is said to consciously direct healing energy through his or her hands to the subject for the purpose of helping or healing. The TT method has been defined as a healing process which requires the practitioner to: (1) center his/herself both physically and psychologically and focus on their intent to therapeutically assist the subject, (2) attune to the energy field of the subject by scanning with the hands 2–6 inches from the body in order to detect imbalances or blocks within the energy field, and (3) consciously redirect and rebalance the energy in those areas of blockage or tension by holding the hands 2–6 inches from the subject's body over the affected area (Lionberger, 1985; Krieger et al., 1979).

Initial studies which were conducted on the laying on of hands process found increases in the rate of wound healing in mice (Grad, Cadoret, and Paul, 1961), an increase in activity of trypsin *in vitro* (Smith, 1973), and an elevation of serum he-

moglobin values in humans (Krieger, 1972, 1973, 1974). Subsequent TT research has suggested that the method may elevate serum hemoglobin in humans (Krieger, 1975), induce a state of deep relaxation as indicated by alterations in EEG, EKG, and GSR (Krieger et al., 1979), decrease "A-State anxiety" as measured by the Self-Evaluation Questionnaire STAI Form X-1 (Heidt, 1981; Quinn, 1982, 1984), decrease subjective measures of tension headache pain (Keller, 1983; Keller and Bzdek, 1986), and accelerate human dermal wound repair (Wirth, 1990; Wirth, Richardson, Eidelman, and O'Malley, 1993).

The theoretical principle behind TT, that of an interaction of energy fields without physical contact, was originally formulated by Kunz and Krieger (Krieger, 1990; Macrae, 1979), and demonstrated by Quinn (1982). This noncontact approach to TT has been used in at least five other studies to date (Fedoruk, 1984; Keller and Bzdek, 1986; Meehan, 1985; Wirth, 1990; Wirth, Richardson, Eidelman, and O'Malley, 1993). The present study differed from these experiments by utilizing animals as subjects and examined the effect of four noncontact therapeutic touch (NCTT) healers on the regeneration rate of surgically amputated salamander forelimbs.

Materials and Methods

Adult newts, *Notophthalmus viridescens*, were obtained from a commercial supplier (Berkshire Biological, Florence, MA). Only animals which took food readily, were healthy, of normal form, and weighing between 1.20–2.30 gm were used.

The animals were kept in pH-balanced, dechlorinated tapwater in 20 gallon aquaria containing 1:100 Holtfreter's solution maintained at 25° C with 7 newts per tank. The tanks were cleaned daily and the animals were individually fed beef liver two times a week. Except for the bi-weekly feeding and experimental periods, the newts were kept in semi-darkness with the amount of light constant for all groups throughout the experiment.

A total of 154 salamanders were anaesthetized with 1.0% 3-aminobenzoic acid ethyl ester (MS-222), and one forelimb was randomly amputated using sharp scissors through the distal third of the humerus under sterile conditions. The amputations were performed during the late spring and the protruding humeral stump was trimmed flush with the retracted edges of the soft tissue at the amputation site to give a flat wound surface.

Limb regeneration was assessed using two criteria: (1) the time of first finger differentiation, and (2) the time of fourth finger differentiation. These assessment criteria were chosen due to the fact that measurement by stages is considered to be more accurate than measurement of limb length in millimeters (Pritchett and Dent, 1972), and also because of the precise timing of finger differentiation noted in earlier studies (Schauble, 1972; Schauble and Nentwig, 1974). The regeneration rate of each salamander was assessed daily using a dissecting microscope and the number of days required to attain first and fourth finger differentiation was recorded for each individual animal.

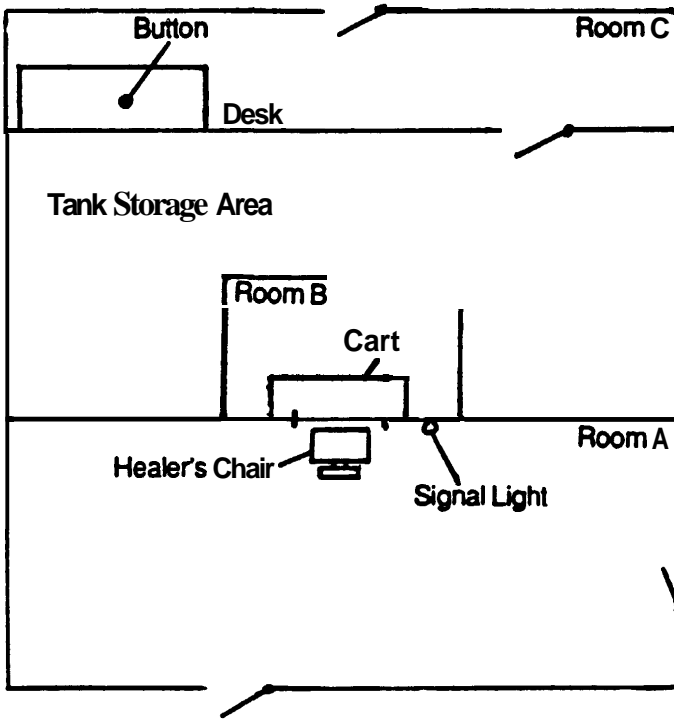

Fig. 1. Experimental Set Up.

The experiment was divided into two sections. The first section of the study utilized 4 noncontact therapeutic touch (NCTT) healers working individually under three separate conditions in a specially designed laboratory (Figure 1).

For the first condition in section #1 of the experiment, the healer entered the laboratory (Room A) and sat in front of an opening in the wall which was slightly smaller than the longitudinal side of the 20 gallon aquaria used (Figure 2). The aquarium to be worked on (dimensions: 24" \times 12" \times 16") was in Room B and had previously been placed against the opening in the wall by an independent experimenter (E1) (Figure 3). E1 was informed that a healing study was being conducted but was unaware of which aquaria were in the treatment and control groups. The aquarium for condition 1 was positioned flat against the opening in the wall so that the entire aperture was covered by the side of the aquarium (Figure 3). Once the healer had entered Room A (Figure 1), E1 who was in Room C pressed a button on the desk which turned on the signal light in Room A. This was the signal for the healer to place her hands on the glass of the aquarium and begin performing NCTT. Exactly 5 minutes later, E1 pressed the button again which turned off the signal light in Room A. The healer then removed her hands from the tank.

For condition 2 section #1 of the experiment, the healer positioned a plate of one-half inch smoked opaque glass over the aperture in the wall in Room A (Figure

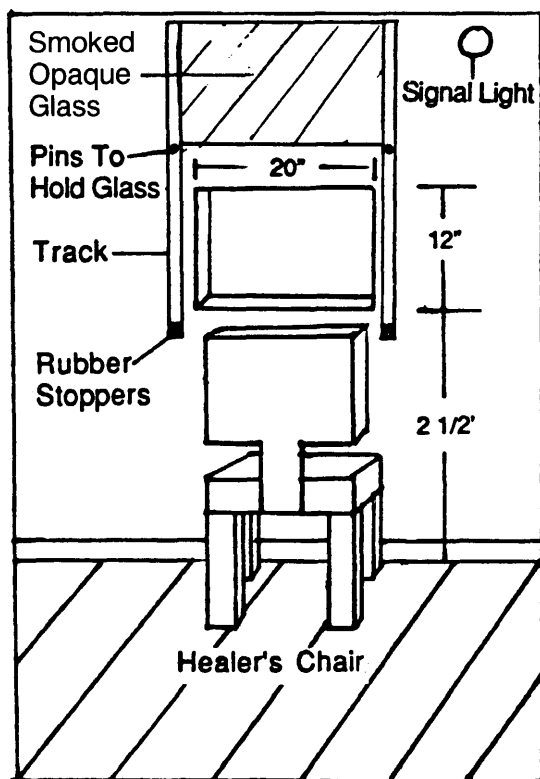

Fig. 2. Detail Room A.

2). For this condition, the healer simply removed the pins which secured the smoked opaque glass and then guided the glass along the track until it came to rest on the rubber stoppers. Condition 2 was incorporated into the study in order to determine whether or not keeping the salamanders out of the healers' sight would effect the degree of healing which occurred. Once E1 had turned off the signal light for condition 1, he removed the tank of salamanders from in front of the opening in the wall in Room B. He then waited 10 minutes, rolled a new tank of salamanders in front of the opening, and reentered Room C where he pressed the button which turned on the signal light in Room A. After receiving this signal, the healer began performing NCTT by placing her hands on the smoked opaque glass until the signal light was turned off by E1 5 minutes later.

For condition 3 section #1 of the experiment, E1 placed a sheet of one-half inch plastic against the opening in the wall in Room B (Figure 3). Condition 3 was incorporated into the experiment in order to determine whether or not a synthetic substance such as plastic would have an effect on the healing process. After following the same procedure as in condition 2 and putting the new tank in place, E1 reentered Room C and pressed the button which signalled the healer to place her

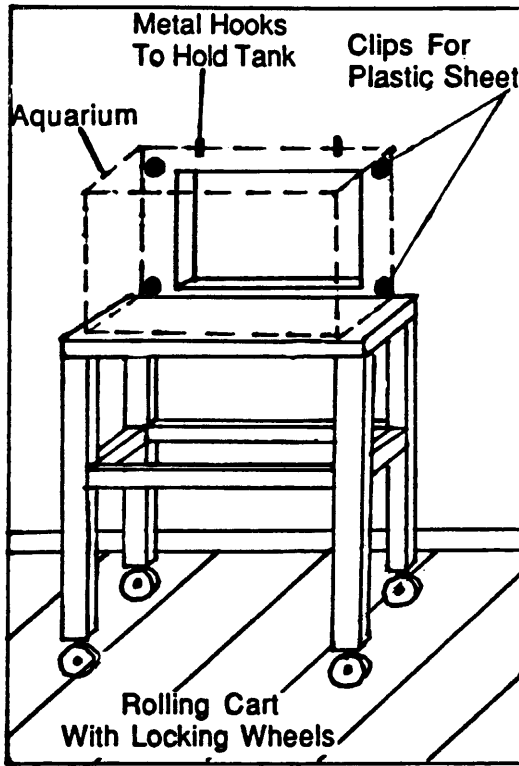

Fig. 3. Detail Room B.

hands on the smoked opaque glass and begin performing NCTT. Once again, the signal light was turned off by E1 exactly 5 minutes later. The control group was established by following the same procedure as outlined above in conditions 1 through 3 using an independent experimenter (E2). E2 was informed that the study was designed to examine the effect of a human presence on the regeneration rate of salamander forelimbs. E2 was instructed to place her hands directly on the tank (condition 1) and the smoked opaque glass (conditions 2 and 3) and to simply sit and relax for the 5 minute sessions. For section #1 of the experiment, the 4 independent healers and E2 entered the laboratory once per day at predetermined times for a 20 day period.

The second section of the study utilized the same 4 healers in the following pairs:

Healer 1 - Healer 2	Healer 2 - Healer 3
Healer 1 - Healer 3	Healer 2 - Healer 4
Healer 1 - Healer 4	Healer 3 - Healer 4

This section was incorporated into the methodological design due to the fact that the prior pilot study run for the experiment had utilized 2 healers (healer 1 and healer 3) who performed NCTT in the same room at the same time on different tanks of newts. It was, therefore, determined that the design of the prior pilot study had created the possibility of a meditative group healing effect which could be examined in the formal experiment by having the healers work in pairs. The pair entered the laboratory (Room A), sat on opposite sides of an aquarium situated in the center of the room, placed their hands directly on the glass, and performed NCTT for 5 minutes. A new aquarium equipped with a fine wire mesh over the top was used for each pair and the control group was established by having two independent experimenters (E2 and E3) sit on opposite sides of an aquarium with their hands directly on the tank. E3 had also been informed that the experiment was designed to examine the effect of human presence on the regeneration rate of salamander forelimbs and was told to simply place her hands on the tank and relax for the 5 minute sessions. Each pair entered the laboratory and performed NCTT once per day for a 20 day period.

During both sections of the study, EEG, skin temperature, heart rate and blood pressure readings were taken from each healer as well as E2 and E3 in order to determine the general parameters of these measures for the healing and control sessions. The figures obtained were then correlated with the results demonstrated by the controls as well as the individual and paired healers. Also, for both sections of the study the healers and E2 and E3 treated the tanks of water for 5 minutes prior to the introduction of the salamanders. This approach was included in the experimental protocol due to the fact that prior research has indicated that water treated by an alternative healer can significantly effect the recovery time of goitre infected animals (Grad, 1965, 1967), the growth of plants (Grad, 1963), and also produce changes in the absorption spectra in the infrared range (Dean and Brame, 1975; Schwartz, DeMattei, Brame, and Spottiswoode, 1990). Therefore, because the newts utilized in the study were still in the aquatic stage, it was determined that pretreatment of the tanks of water by the healers and E2 and E3 would be an important inclusion in the methodological design.

In addition, the healers were asked to keep a detailed journal and complete a modified version of the SETTS questionnaire for all segments of the study (Ferguson, 1986). The journals and questionnaires, along with an extensive interview conducted after the study, were incorporated into the experimental protocol in order to analyze the phenomenological processes of the individual and paired healers and the possible correlation of these processes with the results obtained.

Results

Data were statistically analyzed using an analysis of variance followed by independent means t-tests to examine the differences in means of the treatment versus the control groups for each individual healer for all 3 conditions for section #1, and for each pair of healers versus the control for section #2 of the experiment. During inspection of the salamanders, it was determined that 2 of the 28 in the

TABLE 1
Time in Days to First Finger Differentiation Stage

T = TREATMENT C = CONTROL C1-3 = CONDITIONS 1-3									
	HEALER 1		HEALER 2		HEALER 3		HEALER 4		
	T	C	T	C	T	C	T	C	
C1	23.57 ± .57	24.29 ± .81	18.43 ± .72*	24.29 ± .81	21.00 ± .49 ^o	24.29 ± .81	23.57 ± .65	24.29 ± .81	
C2	26.29 ± .75	26.71 ± .68	23.00f.62**	26.71 ± .68	26.14 ± .67	26.71 ± .68	23.14 ± .60*	26.71k.68	
C3	24.71 ± .64	25.57 ± .75	21.43 ± .65**	25.57 ± .75	24.86 ± .88	25.57 ± .75	22.43 ± .57**	25.57 ± .75	

Figures are presented as mean ± SEM

* = significant at $p < .002$.

** = significant at $p < .01$.

^o = significant at $p < .04$.

† = significant at $p < .02$.

†† = significant at $p < .05$.

control groups and 4 of the 126 in the treatment groups were not normally formed at the fourth finger differentiation stage and therefore would not be included in the statistical analyses. For both sections of the study, the Bonferroni technique was applied to correct the Type 1 error due to the calculation of multiple comparisons.

Tables 1 and 2 summarize the data for section #1 of the study for healers 1 through 4 for the three experimental conditions at the first and fourth finger differentiation stages. Healer 1 demonstrated complete nonsignificance for all 3 conditions, while healer 2 showed a statistically significant effect at both differentiation stages for condition 1 ($t = 5.41$; $df = 12$; $p < .002$; 2 tailed), and for conditions 2 and 3 at the $p < .01$ level. Healer 3 showed significance during condition 1 only for both first and fourth finger differentiation ($t = 3.48$; $df = 12$; $p < .04$; 2 tailed), while healer 4 demonstrated significance for condition 2 at the $p < .02$ level, and condition 3 at the $p < .05$ level. Figures 4 and 5 show the results of healer 2 versus control for all 3 conditions for both first and fourth finger differentiation stages, and

TABLE 2
Time in Days to Fourth Finger Differentiation Stage

T = TREATMENT C = CONTROL C1-3 = CONDITIONS 1-3									
	HEALER 1		HEALER 2		HEALER 3		HEALER 4		
	T	C	T	C	T	C	T	C	
C1	29.57 ± .48	30.29 ± .75	24.86 ± .67*	30.29 ± .75	27.14 ± .51 ^o	30.29 ± .75	29.67 ± .72	30.29 ± .75	
C2	32.29 ± .68	33.17 ± .79	28.57 ± .78**	33.17 ± .79	32.57 ± .65	33.17 ± .79	29.29 ± .64*	33.17 ± .79	
C3	31.17 ± .48	32.00 ± .93	27.57 ± .57**	32.00 ± .93	31.33 ± .96	32.00 ± .93	28.43 ± .57**	32.00 ± .93	

Figures are presented as mean ± SEM

* = significant at $p < .002$.

** = significant at $p < .01$.

^o = significant at $p < .04$.

† = significant at $p < .02$.

†† = significant at $p < .05$.

HEALER 2: FIRST FINGER DIFFERENTIATION

CONDITION1 CONDITION2 CONDITION3

Fig. 5. Healer 2: Fourth Finger Differentiation.

HEALER 4: FIRST FINGER DIFFERENTIATION

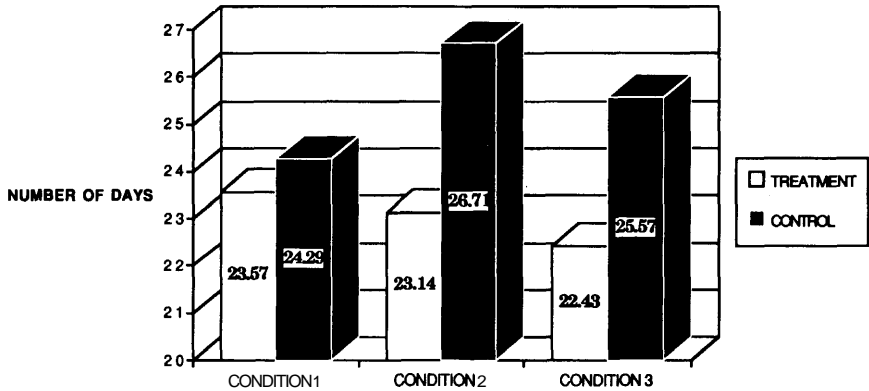

Fig. 6. Healer 4: First Finger Differentiation.

through the distal third of the stylopodium in the newt, *Notophthalmus viridescens*.

Prior research has demonstrated that the rate of regeneration of vertebrate appendages is affected by such factors as temperature (Schmidt, 1968; Schauble and Nentwig, 1974), light cycle (Maderson and Salthe, 1971), and season of the year (Schauble, 1972). It is unclear whether age or body size of adult urodeles has any effect on the rate of regeneration (Iten and Bryant, 1973). Previous research, for example, has shown that age and body size have no apparent influence on the regeneration rate (Manner, Zapisek, and Vallee, 1960; Goodwin, 1946). However, a

HEALER 4: FOURTH FINGER DIFFERENTIATION

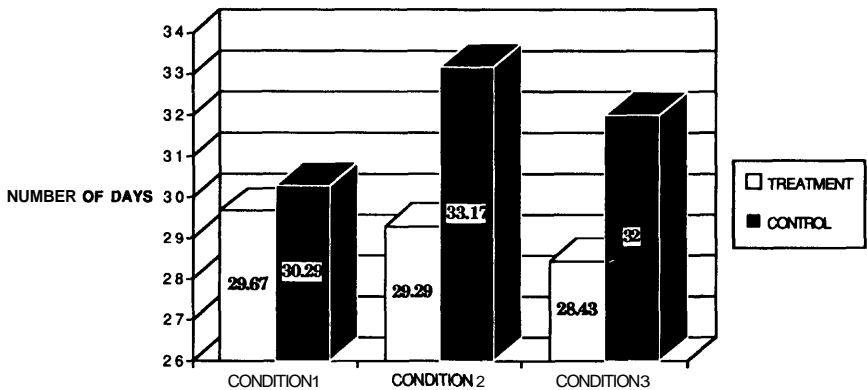

Fig. 7. Healer 4: Fourth Finger Differentiation.

TABLE 3
Finger Differentiation Data for Pairs

PAIR	FIRST FINGER		FOURTH FINGER	
	1-2	22.71 ± .75	23.43 ± .48	29.29 ± .89
1-3	19.43 ± .65*	23.43 ± .48	25.00 ± .79*	30.14 ± .60
1-4	23.14 ± .51	23.43 ± .48	29.43 ± .72	30.14 ± .60
2-3	22.57 ± .65	23.43 ± .48	29.00 ± .72	30.14 ± .60
2-4	23.14 ± .60	23.43 ± .48	29.50 ± .76	30.14 ± .60
3-4	22.29 ± .64	23.43 ± .48	29.14 ± .80	30.14 ± .60

* = significant at $p < .002$

more recent study by Pritchett and Dent (1972) assumed that the age of the newt was proportional to its size and demonstrated that the rate of regeneration was greater in the smaller and, therefore, younger newts. In the current experiment, the temperature, light cycle, season of the year, and size of the animals were kept constant for both treatment and control groups. It is, therefore, unlikely that these factors contributed significantly to the differences observed in the regeneration rate between the two groups.

The assessment criteria of first and fourth finger differentiation were used in both sections of the experiment because these stages are readily observed with the use of a dissecting microscope. In addition, newts were utilized as subjects due to the fact that animals are presumably not susceptible to such psychosocial variables as suggestion, expectation, or the placebo effect. Therefore, the use of animals as subjects, the distinct character of the regenerative stages observed, and the accuracy of the measurement system utilized add confidence to the statistically significant results obtained.

The data contained in Tables 1 and 2 show that a significant effect was obtained at both first and fourth finger differentiation by healer 2 during all 3 conditions, by healer 3 during condition 1 only, and by healer 4 during conditions 2 and 3. In attempting to explain the different results for the individual healers, it was noted that healer 1 and healer 3 had both demonstrated significant results in the prior pilot study run for the experiment. In order to account for the significance obtained in the prior pilot study and the lack of significance in the formal experiment for healers 1 and 3, as well as the consistent and inconsistent significance for healers 2 and 4, respectively, the daily journals kept by all healers were analyzed.

Healer 1 was chosen for this experiment due to the fact that she had obtained highly significant results in a prior experiment which examined the effect of NCTT on the healing rate of full thickness human dermal wounds (Wirth, 1990). The healer's journal for the current experiment and her comments during the post-study interview revealed that she was uncomfortable working with animals and that the significant results which she had obtained during the prior pilot study had placed her in a competitive mode with the other healers which caused her to focus on proving herself rather than on accelerating the regeneration rate of the salamanders. Her discomfort with the use of salamanders as subjects and an inability to focus during the healing sessions may have contributed to the nonsignificant re-

sults she obtained during conditions 1 through 3. It should also be noted that the EEG machine was not used during the prior pilot study and may have adversely affected healer 1 during the formal experiment.

Healer 2 had also obtained highly significant results in a prior experiment which analyzed the effect of NCTT through a one-way mirror on the healing rate of human dermal wounds (Wirth, Richardson, Eidelman, and O'Malley, 1993). The healer's journal for the current study and interview records indicated a comfort with the experimental setting and also revealed that she was highly motivated to heal the salamanders because she felt an affinity with animals in general and periodically worked with them in her healing practice. It is, therefore, suggested that the consistently significant results obtained by healer 2 for all 3 conditions may have been due, in part, to the level of comfort and affinity she felt with the experimental setting and the subjects utilized. In addition, it was noted that for certain periods of time during the study healer 2's hands were folded comfortably in her lap and not on the glass of the aquarium or the smoked glass in front of her. Also, during the interview healer 2 revealed that she routinely closed her eyes for the first few minutes of each healing session. These were interesting observations to note because they may indicate that another form of healing was occurring for healer 2 or that the utilization of the traditional formalized NCTT process is not necessarily a prerequisite for an accelerated healing effect to occur.

Healer 3 was a well known TT practitioner whose journal and interview transcripts indicated that during conditions 2 and 3 of the experiment she was distracted by the fact that the animals were not in view. She indicated that her need to have the subjects in sight disrupted her concentration which may explain, in part, the nonsignificant results she obtained during these 2 conditions. She also expressed a desire to receive periodic feedback about her progress—a procedure which was followed during the prior pilot study but not during the formal experiment. In addition, it is important to note that the use of the EEG machine during the formal experiment may have had a deleterious effect on healer 3's performance. It appears, then, that for healer 3 feedback and an experimental setting which does not utilize an EEG machine may be important components of an effective healing encounter.

Healer 4 was specially trained in the traditional NCTT method for this study and was incorporated into the design due to the fact that NCTT is considered to be a natural human healing potential. The healer's journal and interview records revealed an extreme fear that the newts would leave the tank during condition 1 which precluded her ability to concentrate and may have contributed to the nonsignificant results obtained during this condition. The use of smoked opaque glass during conditions 2 and 3, however, relieved this fear and allowed her to focus on a desire to help or to heal. It is interesting to note that she achieved less significance for condition 3 (through smoked glass and plastic), than for condition 2 (through smoked glass only). A possible reason for this differential effect by the same healer may be that the healing energy transferred from healer to patient is somehow inhibited by synthetic substances such as plastic. This explanation, however, cannot be applied to healer 2 who obtained an equal degree of significance during both conditions 2 and 3. It, therefore, appears that plastic may inhibit the transfer of

healing energy for some healers (healer 4), while not affecting the transfer for others (healer 2).

Although the observations contained in the journals for section #1 of the experiment were not standardized and, therefore, were not statistically analyzed, they do suggest that such psychosocial variables as a competitive orientation (Healer 1) and an inability to focus or concentrate (healer 3 conditions 2 & 3, and healer 4 condition 1) may prove detrimental to the healing encounter. In addition, the phenomenological data for the individual healers appear to indicate that adherence to a particular healing method or ritual is not necessary for a positive healing effect to occur.

The results obtained during section #2 of the experiment demonstrated that only the pair of healer 1-healer 3 obtained a significantly accelerated rate of regeneration (Table 3). This section was incorporated into the experiment in order to examine the possibility that a meditative group healing effect had occurred during the prior pilot study. An analysis of the healers' journals and interview records for this section of the experiment was undertaken and indicated that healer 2 preferred to work alone because she could sense and feel the other healers and found it to be distracting, while healer 4 reiterated her extreme fear that the newts would escape from the tank in front of her. The journals and interview transcripts of healers 1 and 3, in contrast, indicated a deep mutual respect and affection for each other and a willingness to work together. It is suggested that the connection and bond between healers 1 and 3, which was due to their 10 year long friendship, may have facilitated the accelerated healing effect demonstrated by the prior pilot study and section #2 of the experiment.

For both sections 1 and 2 of the study, EEG, skin temperature, heart rate and blood pressure readings were taken from the healers and controls in order to examine the possible correlation between these physiological measures and the healing effects which occurred. In general, the controls demonstrated EEG readings in the beta range along with skin temperature, heart rate and blood pressure readings in line with those expected for healthy individuals who are awake and in a relaxed state. For the healers, the EEG readouts were predominantly within the alpha range for healers 1 and 2, while healers 3 and 4 demonstrated readings predominantly within the fast beta range. Similarly, the heart rate and blood pressure readings of healers 3 and 4 were indicative of arousal, whereas healers 1 and 2 demonstrated readings in line with a calm meditative state. In addition, healers 2 and 4 demonstrated a decreased skin temperature, while healers 1 and 3 showed an increase from their pre-study baseline. This was an interesting result due to the fact that stress is normally associated with a decrease in skin temperature while relaxation increases the temperature. Therefore, since healer 2 was physiologically calm and still demonstrated a decreased skin temperature, while healer 3 was physiologically aroused yet showed an increased temperature, it would appear that other factors besides relaxation and stress level played a role in the skin temperature readings obtained. Although the physiological data gathered for this study were preliminary in nature due to the fact that only the predominant trend was determined for each individual measure, the findings are nevertheless of importance because they are

consistent with prior reports which suggested that positive healing effects can occur when the healer is in both a relaxed and physiologically active state (Krieger et al., 1979; Macrae, 1979).

In conclusion, the data of this study appear to indicate that prior healing experience may not necessarily correlate with future experimental success. Numerous factors such as the healer's competitive orientation, the level of concentration attained, and the use of ritualized healing methods may have a significant influence on the outcome of the healing encounter. The statistically significant results obtained by healer 2 for all three conditions, healer 3 for condition 1, and healer 4 for conditions 2 and 3 suggest that NCTT has the potential to accelerate the rate of regeneration of newt forelimbs amputated through the distal third of the stylopodium. Additional analyses which will include a detailed study of the healers' journals and modified SETTS questionnaires along with the interview transcripts will be conducted at a future date in order to evaluate the possible reasons why the four individual and paired healers obtained differential healing effects. Further research is needed in order to evaluate the effect of alternative healing therapy on the rate of regeneration of different parts of the newt. This research could provide the field with a large data base that utilizes a precise and objectively measured dependent variable. Additional studies would benefit by including more sophisticated instrumentation and periodic measurements of EEG, skin temperature, heart rate and blood pressure and could also examine the influence of alternative healing on the rate of regeneration for children and adults with accidentally amputated fingertips.

Acknowledgements

This project was made possible thanks, in part, to the generosity and support of Jack and Maureen Rogers, Bill Kemple, and Elizabeth H. Carson. In addition, this work owes a special debt of gratitude to Dolores Krieger, Bernard Grad, Murielle Schauble, Marcus Singer and Gertrude Schmeidler for their helpful advice and recommendations.

Correspondence and reprint requests may be directed to Dr. Daniel Wirth at the Healing Sciences Research International.

References

- Becker, R. O., Chapin, S., and Sherry, R. (1974). Regeneration of the ventricular myocardium in amphibians. *Nature*, 248:145-147.
- Davis, B. M., Ayers, J. L., Koran, L., Carlson, J., Anderson, M. C., and Simpson, S. B. Jr. (1990). Time course of salamander spinal cord regeneration and recovery of swimming: HRP retrograde pathway tracing and kinematic analysis. *Experimental Neurology*, 108(3):198-213.
- Dearlove, G. E., and Dresden, M. H. (1976). Regenerative abnormalities in *Notophthalmus viridescens* induced by repeated amputations. *Journal of Experimental Zoology*, 196:251-262.
- Douglas, B. S. (1972). Conservative management of guillotine amputations of the finger in children. *Australian Paediatric Journal*, 8:86-89.
- Fedoruk, R. B. (1984). Transfer of the relaxation response: therapeutic touch as a method for reduction of stress in premature neonates. (*Unpublished doctoral dissertation, University of Maryland*).
- Ferguson, C. K. (1986). Subjective experience of therapeutic touch survey (SETTS): psychometric examination of an instrument (*Unpublished doctoral dissertation, The University of Texas at Austin*).

- Goodwin, P. A. (1946). A comparison of regeneration rates and metamorphosis in *Triturus* and *Ambystoma*. *Growth*, 10:75-87.
- Grad, B. (1963). A telekinetic effect on plant growth. *International Journal of Parapsychology*, 5:117-133.
- Grad, B. (1965). Some biological effects of laying on of hands: a review of experiments with animals and plants. *Journal of the American Psychological Society*, 59:95-127.
- Grad, B. (1967). The 'laying on of hands' implications for psychotherapy, gentling and the placebo effect. *Journal of the Society for Psychical Research*, 61(4):286-305.
- Grad, B., Cadoret, R. J., and Paul, G. J. (1961). An unorthodox method of treatment on wound healing in mice. *International Journal Parapsychology*, 2:5-19.
- Grigorian, E. N., Dol'nikova, A. E., and Belkin, V. M. (1990). Fibronectin distribution during the trans-differentiation and proliferation of eye cells after retinal detachment and removal of crystalline lens in tritons. *Ontogeny*, 21(4):403-408.
- Heidt, P. R. (1991). Helping patients to rest: clinical studies in therapeutic touch. *Holistic Nursing Practice*, 5:57-66.
- Heidt, P. R. (1981). Effect of therapeutic touch on the anxiety level of hospitalized patients. *Nursing Research*, 30:32-37.
- Illingworth, C. M. (1974). Trapped fingers and amputated finger tips in children. *Journal Pediatric Surgery*, 9:853-858.
- Iten, L. E., and Bryant, S. V. (1973). Forelimb regeneration from different levels of amputation in the newt, *Notophthalmus viridescens*: length, rate, stages. *Wilhelm Roux' Archiv*, 173:263-282.
- Keller, E. (1983). The effects of therapeutic touch on tension headache pain. (Unpublished Masters thesis, University of Missouri - Columbia).
- Keller, E., and Bzdek, V. M. (1986). Effects of therapeutic touch on tension headache pain. *Nursing Research*, 35:101-106.
- Kiortsis, V., Koussoulakos, S., and Wallace, H. eds. (1988). *Recent trends in regeneration research*. Plenum Press, New York, v pp.
- Krieger, D. (1972). The response of in vivo human hemoglobin to an active healing therapy by direct laying on of hands. *Human Dimensions*, 1:12-15.
- Krieger, D. (1973). The relationship of touch with the intent to help or to heal, to subjects in vivo hemoglobin values: a study in personalized interaction. *Proceedings of the Ninth American Nurses Association Research Conference, American Nurses Association, New York*, pp. 39-58.
- Krieger, D. (1974). Healing by the laying on of hands as a facilitator of bio-energetic change: the response of in vivo human hemoglobin. *Psychoenergetic Systems*, 1:121-129.
- Krieger, D. (1975). The imprimatur of nursing. *American Journal of Nursing*, 5:784-487.
- Krieger, D. (1979). *The therapeutic touch: how to use your hands to help or heal*. Prentice-Hall, New Jersey.
- Krieger, D. (1990). Therapeutic touch: two decades of research, teaching, and clinical practice. *Imprint*, 3:83-88.
- Krieger, D., Peper, E., and Ancoli, S. (1979). Therapeutic touch: searching for evidence of physiological change. *American Journal of Nursing*, 4:660-662.
- Lionberger, H. J. (1985). An interpretive study of nurses' practice of therapeutic touch (Unpublished doctoral dissertation, University of California at San Francisco, microfilm #382).
- Liozner, L. D. (1974). Organ regeneration: a study of developmental biology in mammals. *Consultants Bureau*, New York, 1-15 pp.
- Louis, D. S., Palmer, A. K., and Burney, R. E. (1980). Open treatment of digital tip injuries. *Journal of The American Medical Association*, 244:697-698.
- Macrae, J. (1979). Therapeutic touch in practice. *American Journal of Nursing*, 4:664-665.
- Maderson, P. F. A., and Salthé, S. N. (1971). Further observations on tail regeneration in *Anolis Carolinensis* (Iguanidae Lacertilia). *Journal of Experimental Zoology*, 177:185-189.
- Manner, H. W., Zapisek, W. F., and Vallee, J. A. (1960). The effect of body size on the rate of salamander limb regeneration. *Anatomical Record*, 137:378.
- Meehan, T. (1985). The effect of therapeutic touch on the experience of acute pain in post-operative patients. (Unpublished doctoral dissertation, New York University).
- Oberpriller, J., and Oberpriller, J. C. (1971). Mitosis in adult newt ventricle. *Journal of Cell Biology*, 49:560-563.
- Platt, A. (1910). De generatione animalium. In: *The works of Aristotle*, v. 5 (1912) Smith, A. J., Ross, W. D. Eds., Oxford, Clarendon Press.
- Pritchett, W. H., and Dent, J. N. (1972). The role of size in the rate of limb regeneration in the adult newt. *Growth*, 36:275-289.

- Quinn, J. F. (1982). An investigation of the effects of therapeutic touch done without physical contact in state anxiety of hospitalized cardiovascular patients. (*Unpublished doctoral dissertation, New York University, 1982, Microfilm #DA8226788*).
- Quinn, J. F. (1984). Therapeutic touch as energy exchange: testing the theory. *Advances in Nursing Science*, 6:42-49.
- Schauble, M. K. (1972). Seasonal variation of newt forelimb regeneration under controlled environmental conditions. *Journal of Experimental Zoology*, 181:281-286.
- Schauble, M. K., and Nentwig, M. R. (1974). Temperature and prolactin as control factors in newt forelimb regeneration. *Journal of Experimental Zoology*, 187:335-344.
- Schmidt, A. J. (1968). *Cellular biology of vertebrate regeneration and repair*. University of Chicago Press, Chicago, 420 pp.
- Singer, M. (1952). The influence of the nerve in regeneration of the amphibian extremity. *Quarterly Review of Biology*, 27:169-200.
- Singer, M., Weckesser, E. C., Geraudie, J., Maier, C. E., and Singer, J. (1987). Open finger tip healing and replacement after distal amputation in Rhesus monkey with comparison to limb regeneration in lower vertebrates. *Anatomy and Embryology*, 177:29-36.
- Smith, M. J. (1973). Paranormal effects on enzyme activity. *Human Dimensions*, 1:12-15.
- Thouveny, Y. R., Komorowski, T. E., Arsanto, J. P., and Carlson, B. M. (1991). Early innervation of skeletal muscle during tail regeneration in urodele amphibians. *Journal of Experimental Zoology*, 260(3):354-370.
- Wallace, H. (1981). *Vertebrate limb regeneration*. John Wiley and Sons, New York, 2 pp.
- Wirth, D. P. (1990). The effect of noncontact therapeutic touch on the healing rate of full thickness dermal wounds. *Subtle Energies*, 1:1-20.
- Wirth, D. P., Richardson, J. T., Eidelman, W. S., and OMalley, A. C. (1993). Full thickness dermal wounds treated with noncontact therapeutic touch. *Subtle Energies*.