

## A Gas Discharge Device for Investigating Focussed Human Attention\*

WILLIAM A. TILLER

*Department of Materials Science and Engineering, Stanford University,  
Stanford, CA 94305-2205*

**Abstract**—A gas discharge cell with dielectric-coated electrodes and  $\sim 1$  mm gap was operated at voltages  $\sim$  several percent below breakdown for the purpose of measuring an effect of focussed human attention on electron microavalanche size in the gas. An enhanced counting rate of supercritical size microavalanches was observed under a well-defined protocol when focussed human attention was active. It was found that humans can either enhance the microavalanche number and size or leave the system unchanged depending upon their mental focus. Here, the device design as well as the effects of various gases, dielectrics, shielding, etc., are discussed.

### Introduction

Over a decade ago, an extensive study of high voltage photography (Boyers & Tiller, 1973, 1976; Tiller, 1976), more commonly known to the lay public as Kirlian photography (Krippner, 1975; Krippner & Rubin, 1973; Ostrander & Schroeder, 1970), was conducted. Although much of the lay literature in this case is of an extravagant and unsubstantiated nature and, although a number of studies (Boyers & Tiller, 1973, 1976; Pehek, Kyler, & Faust, 1976; Tiller, 1973) pointed to purely conventional electrical discharge phenomena being the dominant features, it was felt that this didn't account for all of the observed features and that there was an unexplained, novel phenomenon involved. It was thought that the novel phenomenon generally produced only a small signal buried within a large signal associated with the conventional electrical discharge. It was further thought that on rare occasions, the novel signal could increase in amplitude relative to the conventional signal and lead to an observable and anomalous effect.

To test for the existence of such a novel phenomenon, it would be necessary to design an experimental setup in which the large signal associated with the conventional electrical discharge was absent. In the present paper one

---

\* Paper presented at the Ninth Annual Meeting of the Society for Scientific Exploration, August 9-11, 1990, Stanford University, Stanford, California.

*Acknowledgments.* I would like to acknowledge the very significant contributions of my former students, Dr's E. M. Young and D. N. Modlin, who performed most of the experimental work for this paper. I would also like to thank Ms. Frances Farrelly for timely and helpful discussions during the design and development phase of this work.

such device is described and some of the experimental findings arising out of a several year long study with the device are presented. It will be shown that this is essentially a high-gain device that responds to some type of interaction with the human subject so as to yield an enhanced discharge current.

## Experimental

### *Device Design*

The basic device is a high-voltage device but, unlike Kirlian photography, it operates at voltages slightly below rather than above the breakdown voltage. Also, unlike Kirlian photography devices, the voltage is not directly applied to the human body but rather is applied to a thin layer of gas that becomes located in the immediate vicinity of the human. Thus, the biological system is not exposed to a severe electrical perturbation as in Kirlian photography but, instead, attempts to influence what could be called a "passive" detector not unlike a Geiger counter. It is quite different than a Geiger counter, however, in that the design generates a large internal "gain," which will be discussed later.

The actual detector, illustrated schematically in Figure 1, has a sandwich-like shape with the gas isolated between two parallel planar dielectric surfaces separated by  $\sim 10^{-3}$  m. Figure 2 presents a photograph of the assembled device which is  $\sim 10^{-1}$  m from edge to edge and  $\sim 2 \times 10^{-2}$  m thick. Gold electrodes  $\sim 4 \times 10^{-2}$  m in diameter were vacuum sputtered onto the outside of the dielectric surfaces to a thickness of  $\sim 450 \text{ \AA}$ , thus allowing about 70% transmission to daylight but remaining nearly invisible in a dark room if one wishes to observe the glow from the gas discharge. Tinned copper wires (#22), attached around the electrode periphery by a mixture of resinous adhesive and copper paint provided electrical contact.

Quartz, high-lead glass, crown glass and soda-lime glass plates  $\sim 2 \times 10^{-3}$  m thick were utilized as the dielectrics. As shown in Figure 1, the dielectric surfaces were sealed to the phenolic frame structure by means of flat gum rubber gaskets just inside a bolting square of nylon hardware (see Figure 2). The gap spacer section of phenolic contains both an inlet and an exit port,

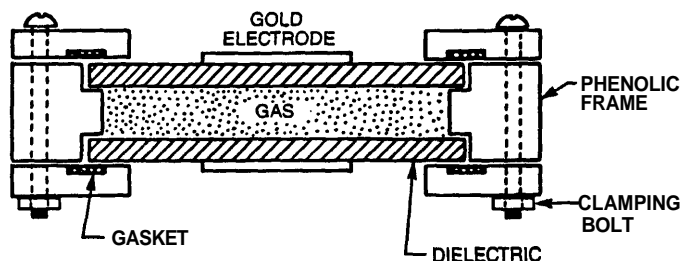

Fig. 1. Schematic of detector cross-section.

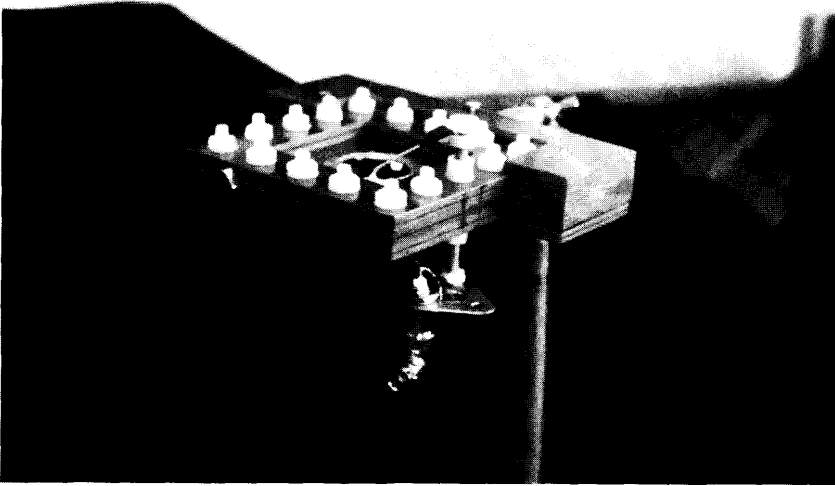

Fig. 2. Photograph of operational detector from the high voltage side.

each terminated by a closure valve, for both changing and isolating the internal gas charged at atmospheric pressure. A number of different gases (Xe, CO<sub>2</sub>, N<sub>2</sub>, air, Xe - CO<sub>2</sub> mixtures) have been used with varying results. These gases were chosen to provide a fairly broad range of discharge properties.

The detector is powered by a finely regulated precision high-voltage system capable of delivering an essentially undistorted sinusoidal voltage between 0-10<sup>4</sup> volts RMS over the frequency range 10<sup>2</sup>-10<sup>4</sup> Hz. However, frequencies between ~10<sup>1</sup>-10<sup>5</sup> Hz were initially explored to discover a viable operating range. The power supply feeds only one of the two gold electrodes while the other electrode is maintained at ground potential. The power supply arrangement is illustrated in Figure 3 (inside the dashed rectangle). The special features of this system are outlined in Appendix I.

The current output from the device passes through a 1-ohm sensing resistor and can be detected by either an oscilloscope or a pulse counter. With such a pulse counter, any current pulse larger than a preset value is recorded as a single count. The minimum detectable pulse has a 5-nanosecond width at a 140 mV pulse height (0.14 amps). The counter used was set to register only positive pulses. A 400 MHz single-beam real-time storage oscilloscope was sometimes employed to display the current versus time characteristics of a single pulse. A typical trace for the electron microavalanche current expected to cross the gas at voltages ~10%-20% below the breakdown threshold is presented in Figure 4. These single avalanches had peak currents from 0.25-10 amps and were typically of ~20-nanosecond duration. The lower

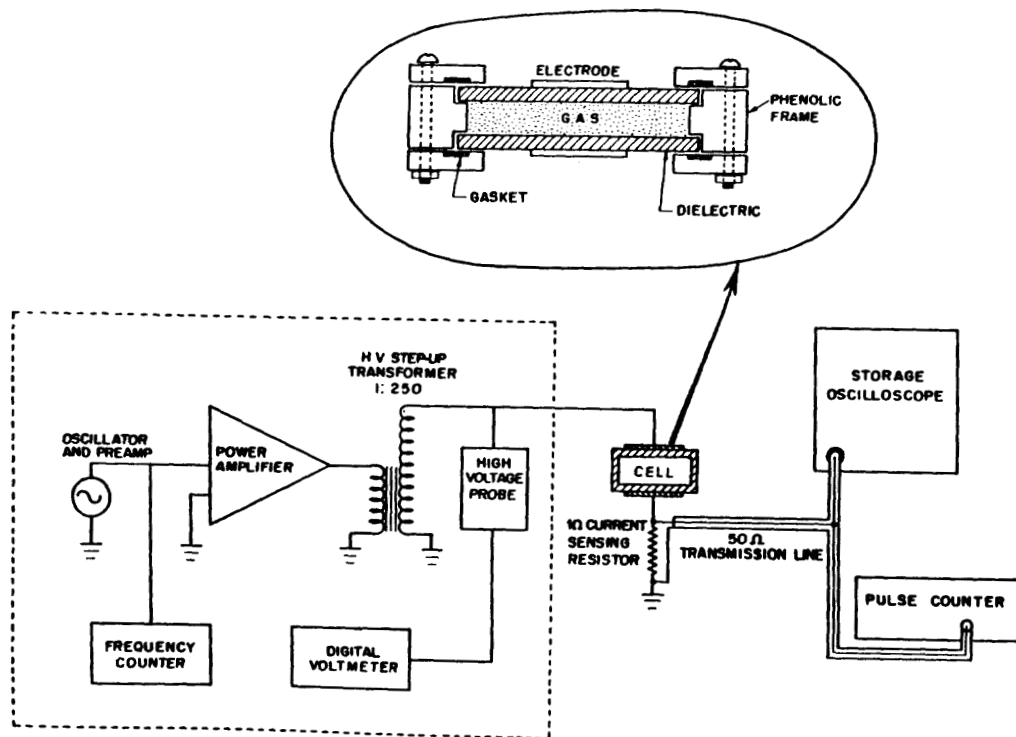

Fig. 3. Schematic of system: Detector, power supply and monitoring system for counting mode and oscilloscope mode. Equipment: Oscillator and preamp custom made (precision); power amplifier—Crown DC 300 A; H.V. step-up transformer—custom made; H.V. Probe—Tektronix P-6015; frequency counter—Fluke 1900 A; digital voltmeter—Fluke 8600 A (4 digit); storage oscilloscope—Tektronix 7834; counter—Hewlett Packard 5328 A.

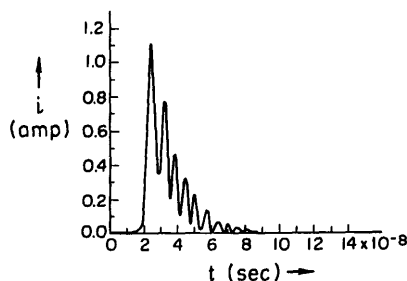

Fig. 4. Typical oscilloscope trace of electron avalanche current vs time; 200 mA/vertical division and  $10^{-8}$  sec/horizontal division.

limit on sensitivity was set by the triggering threshold of the scope which was  $\sim 0.1$ – $0.4$  amps.

It is well known that, in the discharge region below the breakdown threshold, microavalanche streamers like those illustrated schematically in Figure 5 ( $n$ ,  $\sim 5 \times 10^{10}$  electrons) are present in the gas. None of these current streamers is large enough to produce a sustained discharge across the gap but, from Figure 4, it should be clear that a single pulse recorded on the counter involves a time-correlated burst or volley of microavalanches. By adjusting the sensitivity of the pulse counter, one can either count volleys with more small current avalanches or only volleys with very large current microavalanches. In the experiments reported here, the counter sensitivity was generally adjusted to just not count the largest microavalanche volleys at the voltage setting; that is, during background or baseline runs, a counting rate of zero was generally selected; however, the counter sensitivity setting sometimes allowed a few counts to be recorded in a five-minute period. Then, the human influence on the device could be detected by an increased number of counts.

This detector resembles an oversized version of a basic plasma discharge cell and has many features in common with one of the cells in a conventional A.C. plasma display panel (PDP) (Jackson & Johnson, 1974). Because of the fundamental physics involved in this area of activity (Penning, 1975), one knows that the magnitude of the current pulses for a given voltage depends upon gas/dielectric geometry, dimensions, dielectric constant and frequency, as well as both the primary Townsend ionization coefficient,  $\alpha$ , of the gas and the secondary Townsend ionization coefficient,  $\gamma$  of the gas/dielectric surface. Thus, if a human subject is able to influence the counting rate of the system, it would be largely via changes in  $\alpha$  and/or  $\gamma$ , and/or the applied voltage via a significant capacitive effect.

#### Test Protocol

After showing that the important human interaction with the device is via a dynamic effect rather than via a static capacitive effect, a variety of experi-

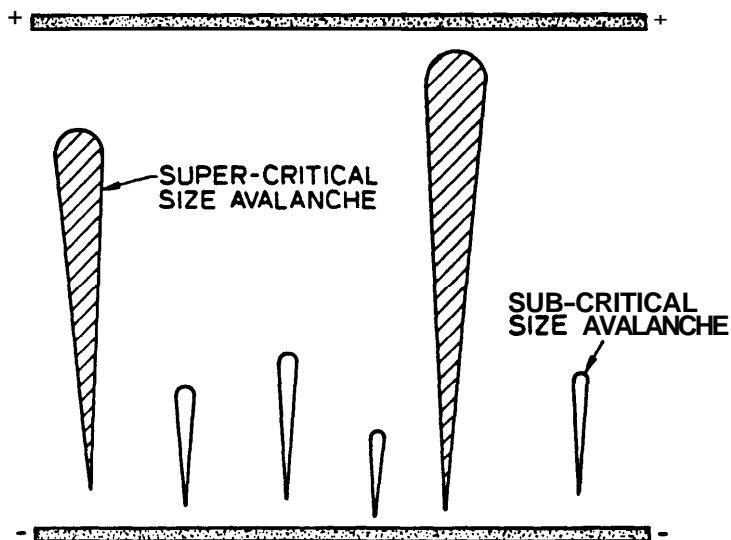

Fig. 5. Illustration of subcritical and supercritical electron avalanche relative size for counting purposes.

ments are used to indicate some features of the dynamic effect. To evaluate this dynamic effect, the following protocol was utilized:

1. The voltage and frequency were set and the pulse height sensitivity adjusted periodically to bring the background counting rate into the desired range (zero to a small number); then the system was allowed to run at this base level for  $\sim 1$  h.
2. Next, the subject stood or sat  $\sim 1$  m in front of the detector, located horizontally at a height of  $\sim 1$  m above the floor, for a period of five minutes without paying any particular attention to the detector. The total counts for this five-minute period were recorded and tabulated as the "without hands" (WOH) result.
3. For the next five-minute period, the subject stood or sat closer to the detector with their hands placed around but not touching the detector (within  $3 \times 10^{-2}$  m) and focussed their attention on increasing the counting rate. The total counts for this five-minute period were recorded and tabulated as the "with both hands" (WBH) result.
4. Next, the subject stepped back to the original position for a period of 5–15 minutes (or sometimes longer) to allow the counting rate to return to the original base-line rate. The counts during this "run-on" period were also recorded.
5. The system was then available for a second test following steps 2, 3, and 4.

During this study, only the instrument aspects were given consideration and no tests were conducted to probe the psychological aspects involved.

## Results

### *Qualitative*

Early experiments showed that, when a subject brought their palm or fingers within  $\sim 5 \times 10^{-2}$  m of the grounded electrode, an intermittent and then often a brief sustained discharge developed in the gas even though the applied voltage,  $V_A$ , was less than the breakdown voltage,  $V_{BD}$ , by several hundred volts ( $V_A/V_{BD} = 0.85-0.90$ ). In a darkened room, the enhanced discharge region associated with a single finger near the detector was seen as a brighter glow in that region compared to the general background glow. Moving the finger led to a movement of the enhanced glow region. When the finger or hand was removed, the enhanced discharge died away. It was also observed that the magnitude of  $V_A/V_{BD}$  needed to produce comparable enhancement effects varied with frequency of the applied voltage with the minimum value of  $V_A/V_{BD}$  occurring around 500 Hz. Since the maximum enhancement effect occurred at such a low frequency, it is unlikely to be a purely capacitance effect. Subsequent quantitative experiments bore this out. When the detector had been freshly filled with a new gas mixture, especially 30% Xe + 70% CO<sub>2</sub>, an initial conditioning period was needed before  $V_{BD}$  settled down to its stationary value. This could be shortened by running the system at  $V_A = V_{BD_0}$  for a few minutes, allowing the system to rest at  $V_A = 0$  for 10-15 minutes, running the system at  $V_A = V_{BD_1}$  for a few minutes, allowing the system to rest at  $V_A = 0$  for 10-15 minutes, etc. After several hours of this procedure, the cell had generally reached a stable value of  $V_{BD}$  which would stay reasonably constant (see Table 1) for a month or two of intermittent use before beginning to degenerate towards a sporadic behavior with  $V_{BD}$  jumping around unreliably. At this point the cell would be pumped out and refilled with gas and sometimes it was necessary to replace the dielectric plates.

Much of the time, the system worked in a reliable fashion and an enhanced counting rate could be obtained by all subjects ( $\sim 2-10$  on any one day) although with different degrees of enhancement. However, on some occasions, for periods of one to several days, no one was able to produce an enhanced counting rate and we were never able to determine why. No correlation was found with rain storms, phase of the moon, etc.; however, no consideration was given to geomagnetic field activity. On other occasions, it required great effort to produce an enhanced counting rate and, at these times, some subjects could not achieve an enhanced counting rate.

These experiments were conducted mainly over a three year period from 1977 to 1979 and involved several thousand different tests with several

TABLE 1  
Cell conditioning sequence (filled with 30%Xe + 70%CO, at  $t = 0$ )

$t$ (min)	$V_{BD}$ (volts)
0	4,000
10	4,025
20	4,175
30	4,300
40	4,400
50	4,400
60	4,400

dozen different subjects under a wide variety of different experimental conditions. During these experiments, both an "acclimation" and a "fatigue" effect were noted. Here, the total count enhancement of consecutive experimental runs was observed to climb as a subject became less anxious about, and more acclimated to, the experimental conditions. However, this increase was often short-lived as the subject became either fatigued or bored and the total count enhancement of consecutive runs began to drop. The duration of the cycle was sometimes as short as three consecutive experimental runs but usually occurred over five or more runs when subject rest periods were taken between runs.

### Quantitative

Following the standard experimental protocol, a number of experimental results will be presented:

1. *Repetitive sequences with one subject.* Figure 6 illustrates schematically the enhanced counting. If the counting rate during the WOH segment was zero then this persisted for  $\sim 1-2$  minutes into the WBH segment and then sporadic bursts of counts could be heard. These are indicated in Figure 6. At the end of the 5-minute segment, the total number of counts was noted and Table 2 presents typical data-gathering sequences with subject A on two different days. These two sequences were chosen to illustrate some measure of the enhanced counting during the run-on period. In some cases zero additional counts were generated during the run-on period. The WBH case exhibited qualitatively similar behavior to cases when only a single hand was held close to the grounded electrode.
2. *Sequences with several subjects.* Table 3 illustrates typical data gathered on the same day from three different subjects, all of whom independently produced the enhanced discharge activity in the detector using the standard protocol. In general, we have found that nearly every sub-



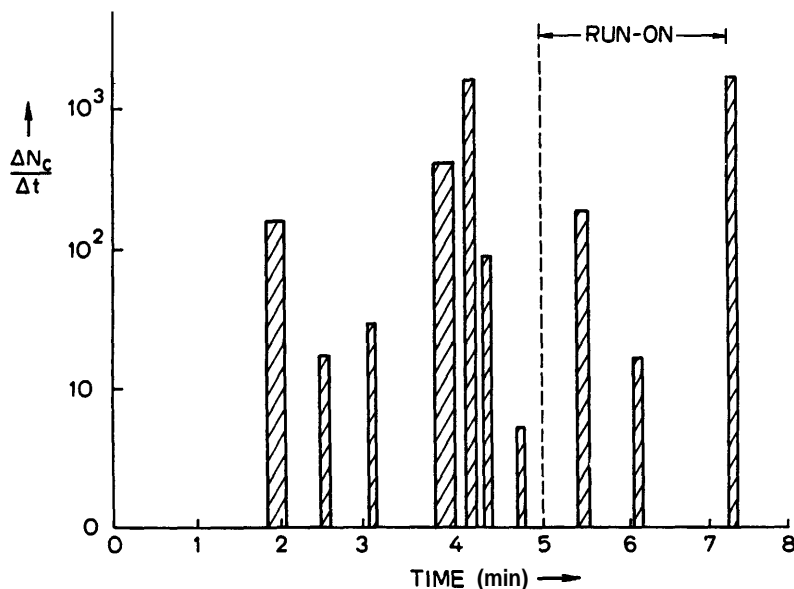

Fig. 6. Schematic illustration of counting rate,  $\Delta N_c/\Delta t$ , as a function of time during a five-minute WBH period and the run-on period.

ject tested ( $-50$ ) has been able to produce some amount of enhanced discharge in the detector. Further, the WBH/WOH ratio has ranged from  $\sim 2:1$  to  $\sim 10^5:1$  while averaging  $-2 \times 10^4:1$ . Low ratios occur when the WOH segment is reasonably large. Young people, old people, students, nonstudents, healers, and nonhealers have been utilized as subjects. The healers did not produce larger ratios than the nonhealers, nor did the young people produce larger ratios than the older people. Generally, from a purely subjective viewpoint, anyone with high ability to focus their attention (their mind) produced a high ratio, while those with only a small ability to concentrate produced a low ratio. Subjects with considerable previous experience using the device generally produced a higher counting rate than new subjects.

3. *Sequences with different nonhuman perturbations and shielding.* Many conventional tests were performed with the detector to see if the enhanced counting effect was a capacitance effect associated with the human body or if the enhanced counting effect could be generated in other ways.

First, to test the capacitance effect, a grounded fine-mesh ( $-0.5 \times 10^{-3}$  m) copper-screen box was constructed to fit completely around the detector with a gap of  $\sim 5 \times 10^{-2}$  m everywhere and serve as a small faraday cage. In all cases, the detector was first completely enclosed in a

TABLE 2  
Typical counting behavior for the detector\*

$V_A$ (volts)	Frequency (Hz)	Time Increment (min)	Hand Condition	Total Counts	Date
4.350	475	5	WOH	0	(1/20/79)
		5	WBH	18,248	
		8	run-on	27,043	
		17	run-on	32,049	
		25	run-on	41,071	
		20	run-on	46,134	
4.325	475	5	WOH	0	(2/13/79)
		5	WOH	0	
		5	WOH	53,972	
		30	run-on	60,672	
		60	run-on	60,672	
		30	run-on	68,293	
		60	run-on	68,293	
		30	run-on	68,293	
		30	run-on	68,293	

\* Subject A, heavy lead glass plus 30% Xe - 70% CO<sub>2</sub> cell.

thin plastic bag before the shield was fitted in place to prevent electrical arcing. The presence of the plastic and the Faraday cage had no apparent effect on the response of the detector during experiments with the normal protocol (see Table 4). Next, an artificial finger and palm-shaped dielectric charged to potentials as high as several kilovolts D.C. had no effect when brought to within  $3 \times 10^{-2}$  m of the grounded electrode.

TABLE 3  
Typical counting behavior for multiple subjects\*

$V_A$	Time Increment (min)	Hand Condition	Counts	Subject
4,350	5	WOH	0	A
	5	WOH	0	
	5	WBH	3,609	
4,350	5	WOH	0	B
	5	WOH	0	
	5	WBH	20,035	
4,350	5	WOH	0	C
	5	WOH	0	
	5	WBH	32,435	

\* Several subjects, high lead glass, air, 475 Hz, 2/9/79.

TABLE 4  
Cell material and shielding variation (475 Hz, air, subject A)

$V_A$ (volts)	Time Increment (min)	Hand Condition	Counts	Date	Special Feature
4,250	5	WOH	2,499	11/8/78	Crown glass dielectric
		WBH	75,606		
4,350	5	WOH	0	1/15/79	High lead glass dielectric
		WBH	35,719		
4,450	5	WOH	0	6/26/79	Soda lime glass dielectric
		WBH	23,531		
4,300	5	WOH	0	2/12/79	Faraday shield (High lead glass)
		WBH	48,721		
4,400	5	WOH	4,741	1/23/79	Magnetic shield on ground side
		WBH	31,453		

As a final test of a possible capacitance effect, the microavalanche volleys were studied to see if the enhanced counting rate was due to an increase in the size of the individual streamers (see Figure 5) in a particular volley or if it was due to an increase in the number of streamers in an average volley. With a high triggering threshold on the oscilloscope, the electrical current generated in a WBH avalanche was generally larger than that generated in a WOH avalanche by factors of  $\sim 2-10$ . However, with a low-trigger threshold and data taken using scope pictures with a high-speed film, the situation was found to be a little different. When exposures were made for both situations (WOH and WBH) such that the same number of total counts were registered on the counter in both cases, the photographic results appeared to be the same; that is, the average discharge profile appeared to be the same for both situations. Of course, for the WBH case, the exposure time was considerably less than for the WOH case. This low-trigger threshold experiment seems to indicate that the enhanced counting rate largely reflects a greater number of microavalanche volleys per unit time rather than a few larger volleys for the WBH case compared to the WOH case. Thus, for the general WBH case, both the rate of microavalanche initiation and the average microavalanche size increase.

The foregoing sequence seemed to indicate that the enhanced counting effect was not due to any appreciable capacitive coupling between the human body and the detector. To investigate some dynamic effects, the detector was first exposed to infrared light at levels commensurate with that of normal body metabolic heat with no enhanced counting rate observed from the detector. As an additional check on the heat radiating possibilities of the human hand, 1/8-inch thick infra red (IR) glass filters, of both the heat absorbing and the heat transmitting variety, were fitted tightly in place adjacent to the detector's grounded electrode. A single

hand of the subject was then brought to within  $-3 \times 10^{-2}$  m of the surface and once again the enhanced counting activity was observed.

Incandescent and fluorescent white light sources of 15 watts located  $-8 \times 10^{-2}$  m from either electrode produced no effect on the counting rate. On several occasions an ultraviolet light source, continuous to 1,500 Å from a 4-watt source centered  $\sim 3 \times 10^{-2}$  m from either electrode, produced no effect on the counting rate. In addition, a medium-strength  $\gamma$ -radiation source ( $C_s^{137}$ ,  $10 \mu\text{Cu}$ ) centered  $-2 \times 10^{-1}$  m from the ground electrode delivered  $-0.8$  mR/h into the gas yet failed to produce any enhanced discharge activity. On one occasion with the ultraviolet (UV) light on, the cell would fire for a count of  $\sim 1,000$  and then stop. If the UV beam was shut off for a minute and then on again, the cell could begin firing again but only for a few hundred additional counts over a five-minute period. Turning the UV off and then on again after another minute wait led to no additional counts. Additional tests of this sort led to no additional count enhancement. This was the full range of our attempts to influence the counting rate through the use of well-defined sources of electromagnetic energy.

In addition to the above, no enhanced counting rate was observed when either a small 50 gauss permanent magnet or a 60 Hz electromagnet of the same strength was brought within  $-2.5 \times 10^{-2}$  m of the grounded electrode. When various thin electrically grounded metal foils (Al, Sn, Cu, Pb, mu-metal)  $-30 \times 10^{-2}$  m square were placed adjacent to the grounded side of the cell ( $\sim 10 \times 10^{-2}$  m square) and a single hand brought up to within  $-2.5 \times 10^{-2}$  m of the cell, the detector still registered an enhanced counting rate (see Table 4). Thus, to date, we have found no material that shields the cell from the WBH effect and we have found no nonhuman device able, reproducibly, to produce an enhancement of the counting rate in the WOH state.

4. *Sequences with different cell materials.* Table 4 shows that the three main dielectrics used in these studies, crown glass, high lead glass, and soda lime glass all behaved well with air as the cell gas and exhibited enhanced counting activity. From several hundred runs with each dielectric, the high-lead glass was found to give the most reproducible behavior with the largest WBH/WOH ratio. With respect to gas variations, Table 5 shows results using a high-lead glass dielectric. Although neither pure  $\text{CO}_2$  nor pure Xe seemed to work too well, the mixture 30% Xe + 70%  $\text{CO}_2$  gave the best results in the sense that subjectively it felt the easiest to influence for producing an enhanced counting rate. Interestingly, the mixture 50% Xe + 50%  $\text{CO}_2$  didn't work nearly as well. Fortunately, both  $\text{N}_2$  and Air worked well although they subjectively seemed to require more effort to produce an enhanced counting rate than the best Xe -  $\text{CO}_2$  mixture.
5. During the experimental period it was sometimes noticed that, with no one in the laboratory but the system running in the WOH mode for a

TABLE 5  
Different gases effect (Subject A, high-lead glass, 475 Hz)

$V_{BD}$ (volts)	$V_A$ (volts)	Time Increment (min)	Hand Condition	Total Counts	Gas	Date
4,690	4,670	5	WOH	0	Air	3/28/79
		60	WOH	0		
		5	WBH	29,890		
		5	run-on	0		
4,830	4,800	15	WOH	0	N <sub>2</sub>	3/28/79
		5	WBH	58,993		
		5	run-on	61,643		
		25	run-on	72,467		
		30	run-on	81,988		
		15	run-on	85,550		
		120	run-on	85,550		
5,170	5,150	15	WOH	0	CO <sub>2</sub>	3/30/79
		5	WBH	0		
		5	WOH	0		
4,400	4,310	5	WOH	0	30% Xe, 70% CO <sub>2</sub>	3/30/79
		5	WBH	54,228		
		5	run-on	54,228		
4,775	4,750	5	WOH	0	Xe	4/6/79
		5	WBH	0		
		5	run-on	7,840		
		5	run-on	17,922		
		5	run-on	17,922		

period of an hour or more with zero or a few total counts, when one of the subjects entered the laboratory the detector would begin chattering and yield  $\sim 10^3 - 2 \times 10^4$  counts before stopping. On other occasions, when in another part of the lab discussing other topics while the system was running in the WOH mode with zero or only a few counts recorded, if attention suddenly turned to matters concerning the cell, the detector would often begin chattering and produce a substantial number of counts. It was dramatic events like these that made us suspect a possible mental influence on electron microavalanche development in the gas.

Two experiments were carried out to test the mental influence effect. In the first, after step 2, and for the next five-minute period, the subject stood or sat in the same location and focussed their attention on increasing the counting rate of the cell without putting their hands around the cell. The total counts for this five-minute period were recorded and tabu-

lated as the "with mind" (WM) result. Next, the subject removed their attention from the cell and moved away from it. Any counts during this run-on period were also recorded. After this, the system was available for a new experiment. During the second major experiment, steps 1, 2, and 4 were the same, but step 3 involved placing the hands around the cell and focussing the attention on an enhanced cell count. Step 5 involved a repeat of step 2 while step 6 is similar to step 3 except that, with the hands around the cell, during the entire WBH counting period the subject withdraws his/her mental concentration from the detector and mentally performed a simple arithmetic addition table; that is,  $2 + 2 = 4$ ,  $3 + 3 = 6$ ,  $4 + 4 = 8$ , . . .  $52 + 52 = 104$ , . . . , etc. During this period the mind is never for a moment allowed to rest on the cell. After step 6 there is another run-on period followed by another step 3 where the attention is focussed into the cell and this is followed by a final run-on period.

Table 6 presents some illustrative results concerning the first experiment wherein, instead of the WBH segment of the standard protocol, a WM segment is used. This experiment clearly shows that the use of the hands is not essential for producing an enhanced counting rate from the detector. Table 7 presents some results for the second experiment where we see that, even though the hands are around the detector but the attention is focussed elsewhere, no enhanced counting rate was observed. During this second experiment it was noticed that an almost irresistible urge developed to focus on the cell, as if a pressure continued to build up until released. It was also noticed during this type of experiment that, if a subject was coming down with a cold and couldn't focus his/her attention too well, it was not possible to maintain a zero counting rate during this segment.

6. To make an initial test of the nonlocal nature of this phenomenon, a subject was placed in a large faraday cage about 10 feet from the detector, which was surrounded by its own Faraday cage. The protocol was essentially the same as the first experiment of 5, except that steps 2 and 3

TABLE 6  
Enhanced counting rate without the use of hands\*

Time Increment (min)	WOH Counts	WM Counts
5	0	6,043
5	920	1,814
5	0	241
5	415	3,864
5	2795	7,016
5	0	7,937
5	3231	12,997
5	0	11,335

\* (Subject A, high-lead glass cell with air, 475 Hz).

TABLE 7  
With both hands but intention focussed on addition\*

Time Segment (min)	Hand Condition	Count Increment	Subject	In'tention Condition
5	WOH	0	C	
5	WOH	0		
5	WBH	53,725		Focus on detector
5	WOH	0		
5	WOH	0		
5	WBH	0		Focus on addition
5	WOH	0		
5	WOH	0		
5	WBH	16,931		Focus on detector
5	WOH	14	A	
5	WBH	11,335		Focus on detector
5	WOH	55		
5	WBH	42		Focus on addition
5	WOH	51		
5	WBH	12,965		Focus on addition
5	WOH	0	D	
5	WBH	23,333		Focus on detector
5	WOH	0		
5	WBH	0		Focus on addition
5	WOH	0		
5	WBH	18,201		Focus on detector

\* (High-lead glass cell with air, 4325 volts, 475 Hz).

required the subjects' location to be inside the 7-foot cubic faraday cage. When the subject focussed his attention on enhanced counting of the detector for a five-minute period, scattered large bursts of counts occurred to change from a zero count condition during stage 2 to about 23,000 counts during stage 3. There was no run-on. Insufficient tests of this type were conducted to constitute a meaningful experiment and it is mentioned here only to point towards some future possibilities. Although it was planned to pursue such faraday cage studies, circumstances didn't allow their materialization at that time.

### Discussion

In this paper, the goal was not to present large amounts of data in quantitative and statistical defense of a **mind/matter** interaction. Rather, it was to present the details of a new electrical device capable of giving large signal response to directed human attention. The hope was that people would be sufficiently interested in the possibilities of such a device that they would build one for themselves and eventually generate such statistical data. Thus, although this three-year study gathered at least two orders of magnitude

more comparable data than is reported here, only a selected sampling has been given to indicate both the dimensions of the study and many key materials aspects of the device.

One should properly ask why this device is so much more effective than a Geiger counter for such a study. Although the Geiger counter is also a poised system, it awaits an ionization event to trigger single microavalanche formation. In the present device, the effect comes, not so much from an initial ionization event but from the memory margin character of the dielectric electrodes (Jackson & Johnson, 1974); that is, at a given applied voltage, a single ionization event leads to single microavalanche formation only in the first half cycle of the wave and this multiplies into a substantial volley of microavalanches during subsequent cycles. In addition, the gas excitation volume of this device is orders of magnitude larger than a Geiger counter. There are other differences between the two types of devices but these are two of the important ones. They make the present type of device a factor of  $\sim 10^4 - 10^6$  more sensitive than a Geiger counter for this kind of study. The detailed considerations of the gain for this kind of device will be given in a subsequent paper. Likewise, possible mechanisms for these human interaction effects will be dealt with at another time.

One thing I would like to do before closing this section is to answer the question "If you had it to do all over again, what would you do differently?" First, I would make some hermetically sealed cells of the same dielectric and compare them with the present "leaky" type of cell. This should remove one major source of contamination and extend the lifetime of a given gas fill. Second, I would measure (photograph the scope trace) the microavalanche volley associated with each setting of the pulse-height counter at each applied voltage between breakdown and 20% below breakdown. Third, I would record the total number of bursts (as in Figure 6) as well as the total number of counts since these are each a significant human/device interaction event. Finally, I would do more experiments remotely at different distances.

### Conclusions

A large-gap plasma display-type of cell and attendant electron avalanche counting circuit has been constructed with sufficient memory margin to respond to human energy fields. It seems that this energy can be directed by the human mind, either into the cell to increase the growth of electron microavalanches or away from the cell so that there is no resultant influence on electron microavalanche size.

### References

- Boyers, D. G., & Tiller, W. A., (1973). *J. Appl. Phys.*, *44*, 3, 102.  
Boyers, D. G., & Tiller, W. A. (1976, March). *Functional Photography*, *11*, 20.



- Jackson, R. N., & Johnson, K. E. (1974). *Advances in electronics and electron physics* (vol. 35). New York: Academic Press.
- Krippner, S., (Ed.). (1975). *Energies of consciousness*. New York: Gordon & Breach.
- Krippner, S., & Rubin, D. (Eds.). (1973). *Galaxies of life: The human aura in acupuncture and kirlian photography*. New York: Gordon & Breach.
- Ostrander, S., & Schroeder, L. (1970). *Psychic discoveries behind the iron curtain*. New York: Prentice Hall.
- Pehek, J. O., Kyler, H. J., & Faust, D. L. (1976). *Science*, 194, 263.
- Penning, F. M. (1975). *Electrical discharges in gases*. New York: McMillan Co.
- Tiller, W. A., (1976). *International Journal of Acupuncture and Electro-therapeutics Research*, 2, 33.

## Appendix I

### *Power Supply Features*

The system can be thought of as containing two distinct boxes. The first box contains the low voltage waveform generation and the control circuitry while the second contains the low voltage to high voltage amplification equipment. Box 2 accepts the signal generated and precisely controlled by box 1. Its job is to faithfully reproduce the signal to voltages up to 15 kV peak and to supply current to a nominal load ( $\sim 10 \text{ pF}$  in parallel with  $50\Omega$ ) at about 10 mA rms when operating continuously at worst case conditions ( $V_p = 15 \text{ kV peak}$ ,  $f = 10 \text{ kHz}$ ). Thus, it is capable of delivering  $\sim 150$  volt-amperes of reactive power.

For box 2, a high-power low-voltage amplifier coupled to a high-voltage output transformer was selected. This choice not only met the design criteria mentioned above but the low-voltage amplifier selected (Crown DC 300A Laboratory Amplifier) was designed for professional stereophonic sound use and thus contained two complete amplifiers on a single chassis. This provided additional reliability and flexibility under varying experimental conditions. The output transistors of the amplifier are operated conservatively and are adequately protected. The protection circuitry is of the sort that does not distort or interfere with the highly transient signals that one wishes the system to amplify.

The transformers were custom designed. Care was taken to optimize performance by choosing high-flux density alloyed transformer cores (4% silicon steel) which extend the low frequency response and, by using four separate windings to minimize high-voltage stress, extend the high-frequency response (by reducing the output capacitance). These components combined to form a high voltage system of unprecedented performance and quality.